

STAND OUT

REPARTO CORSE 2020

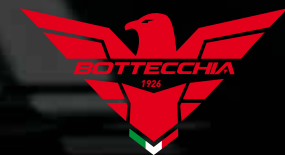

BOTTECCHIA
Reparto Corse





STAND OUT

Distinguiti, fatti notare. STAND OUT è la collezione dedicata a chi vuole distinguersi in modo unico, e ricerca un prodotto di carattere e forte personalità. Forme, design e colori all'avanguardia contraddistinguono questi prodotti dall'inconfondibile stile Bottecchia. Esperienza e tradizione si fondono all'innovazione tecnologica e di design per creare una collezione assolutamente unica.

STAND OUT is the collection dedicated to those who want to stand out in a unique way, and search for a product with character and strong personality. Cutting-edge shapes, designs and colours distinguish these products with the unmistakable Bottecchia style. Experience and tradition blend together technological innovation and design to create an absolutely unique collection.



BOTTECCHIA[®]
Reparto Corse

INDEX

REPARTO CORSE 2020

CORSA



EMME4 SQUADRA
pag. 10



EMME4 SUPERLIGHT
pag. 12



AEROSPACE
pag. 16



T2 DOPPIA CORSA
pag. 20



T1 ENDURANCE
pag. 22



SAVIO REVOLUTION
pag. 24



CRONOTHLON
pag. 26



LEGGENDARIA
pag. 28



DUELLO
pag. 30



ZOLDER
pag. 32



LIEGI
pag. 33



GRAVEL CARBON
pag. 34



GRAVEL MONSTER
pag. 36

MOUNTAIN BIKE HARD TAIL



AQUILA ROSSA TEAM
pag. 40



AQUILA ROSSA
pag. 42



ORTLES 297+
pag. 44



STELVIO 297+
pag. 46



GAVIA 29"
pag. 48



TONALE 29"
pag. 49

FULL SUSPENDED



GARDENA 29" BOOST
pag. 50



FEDAIA 27,5"
pag. 52

FAT BIKE



CERVINO 26"
pag. 54



SENALES 26"
pag. 55

RED LAB

Red Lab è il cuore pulsante delle idee, della tecnologia e di tutta l'innovazione che mettiamo nel Reparto Corse. Dal 2016 il dipartimento ricerca e sviluppo ha voluto puntare ancora più in alto con un laboratorio dedicato allo studio, progettazione e realizzazione di modelli speciali marchiati Red Lab, nella particolare colorazione rosso fluo opaco. Tutte le bici di questa linea sono in carbonio e interamente assemblate a mano in Italia. Questa Special Edition è nata in esclusiva per gli atleti dei nostri team, corsa e mountain bike, che sono stati i primi a testare queste nuove creature dalle incredibili prestazioni.

Red Lab is the beating heart of the ideas, the technologies and all the innovation we use in Reparto Corse. From 2016 the research & development department wants to expand with a laboratory dedicated to the study, the design and the creation of special models, RedLab branded, with the characteristic matt red fluo colour. All the bikes in this range are carbon made and entirely handassembled in Italy. This Special Edition was born for professional athletes of our teams, racing and mountain bikes, who have been the first to test these new creatures with incredible performances.

RED LAB TECHNOLOGIES



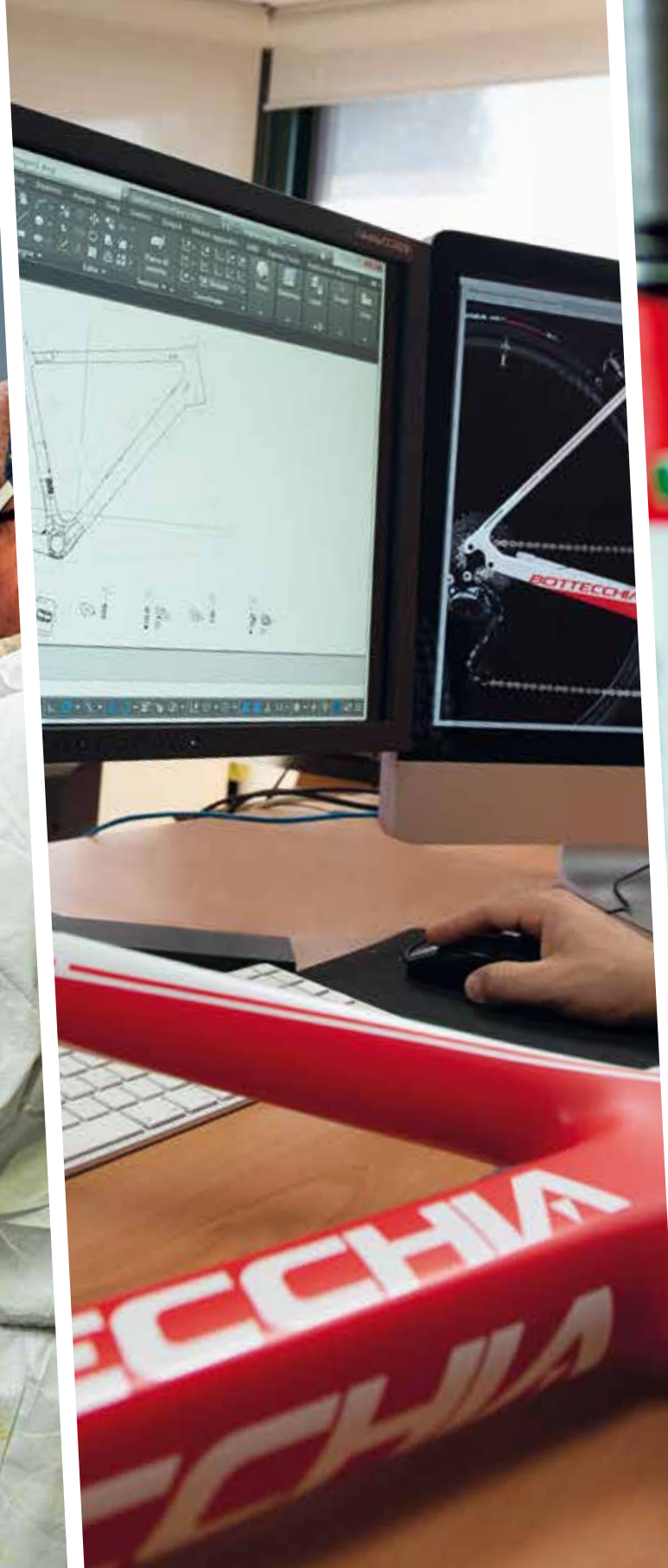



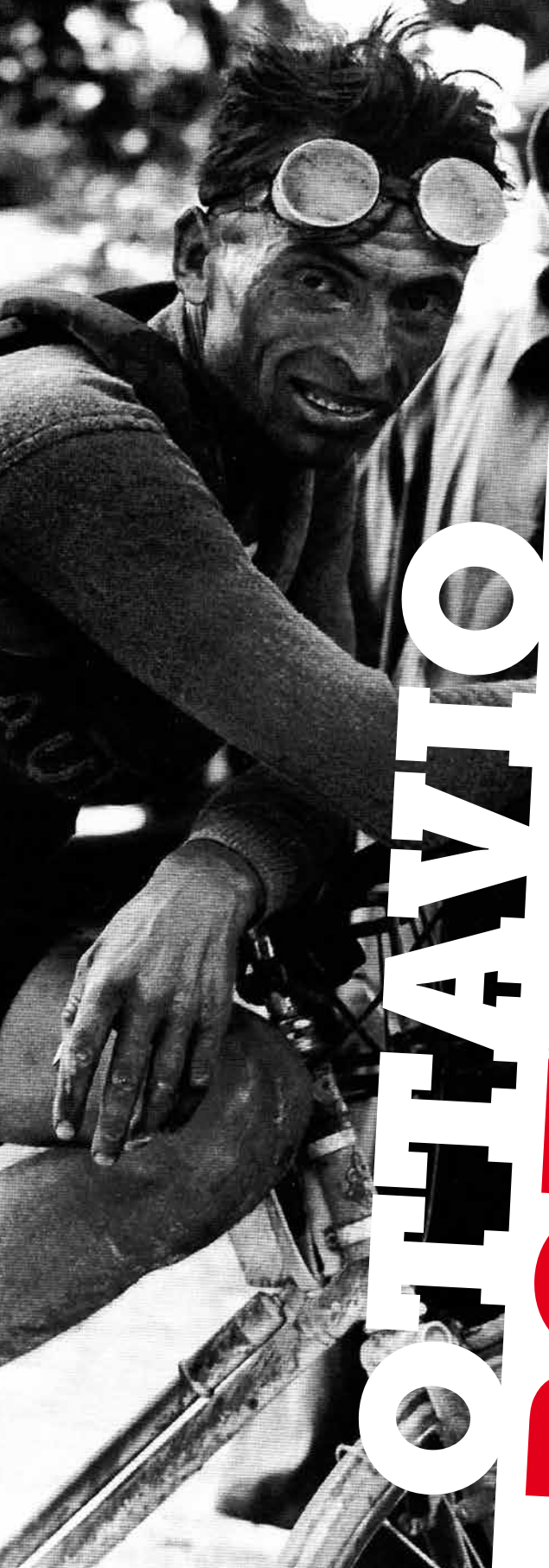

OTTAVIO BOTTECCHIA

Ottavio Bottecchia (San Martino di Colle Umberto, 1 agosto 1894 - Gemona del Friuli 15 giugno 1927) è un mito del ciclismo internazionale, entrato nella storia per essere stato il primo atleta italiano a vincere il Tour de France nel 1924, indossando la maglia gialla dalla prima all'ultima tappa, e a replicare la vittoria l'anno successivo. La sua storia è entrata nella leggenda, strabiliando le folle e stravolgendo il mondo del ciclismo in soli tre anni. Vinse la gara più dura del mondo fuori dai confini della patria, diventando un mito anche oltralpe.

La storia incredibile di un instancabile lavoratore attaccato alla famiglia e alla terra, coraggioso eroe della Grande Guerra, che divenne uno dei più grandi campioni Italiani di tutti i tempi.

Ottavio Bottecchia (San Martino di Colle Umberto, 1st August 1894 - Gemona del Friuli 15th June 1927) is a myth of international cycling, who entered into history for being the first Italian athlete to win the Tour de France in 1924, wearing the yellow jersey from the first to the last stage, and to replicate the victory the following year. His history has become legend, astounding the crowd and shaking the world of cycling in just three years.

He won the toughest race of the world outside the borders of his homeland, becoming a myth also beyond the Alps.

The incredible story of a tireless worker devoted to family and land, brave hero of the Great War, who became one of the greatest Italian champions of all time.



VICTORY OF THE THIRD AND FIFTH STAGE OF THE TOUR OF ALPS



VICTORY OF THE SIXTH STAGE OF GIRO D'ITALIA 2019



ITALIAN CHAMPION TEAM



BOTTECCHIA TECHNICAL SPONSOR TEAM ANDRONI GIOCATTOLI SIDERMEC

Bottecchia ha rinnovato per il quarto anno la partnership con il Team Campione d'Italia Androni Giocattoli Sidermec, presente nel mondo del ciclismo professionistico dal 1996 sempre sotto la guida del Manager Gianni Savio, rappresentando un record di longevità nel ciclismo. Grazie alla perfetta sinergia tra gli atleti Campioni d'Italia e il nostro Reparto Corse, il team è riuscito a guadagnare tantissimi successi nelle competizioni più dure del mondo.

Oggi il Team Androni Giocattoli Sidermec rientra nella categoria Continental Professional partecipando alle gare dei circuiti UCI e guadagnandosi il titolo di Team Campione d'Italia. Con un organico di 20 atleti il Team svolge tripla attività con un calendario di gare nazionali e internazionali in tutti i continenti.

Bottecchia renewed for the fourth year its partnership with the Italian Champion Team Androni Giocattoli Sidermec, which is in the world of professional cycling since 1996, always under the management of Manager Gianni Savio, representing a record of longevity in cycling. Thanks to the perfect synergy between the Italian Champion athletes and our Reparto Corse, the team has managed to gain many successes in the toughest competitions in the world.

Today the Androni Giocattoli Sidermec Team is included in the Continental Professional category by participating in UCI circuit races and earning the title of Champion Team of Italy. With a staff of 20 athletes, the team carries out triple activities with a calendar of national and international competitions on all continents.

PALMARES

17 partecipazioni al Giro d'Italia con 14 vittorie di tappa. 1 Campionato Italiano, 1 Campionato Australiano, 5 Campionati in Colombia, 1 in Irlanda, 3 in Svizzera Romania e Venezuela.

Nella stagione 2017 con bici BOTTECCHIA il Team ha archiviato 100 podi con 25 vittorie in gare ufficiali di calendario UCI International tra le quali, il Tour di Slovacchia, il Tour of Bihor e 1 tappa alla Vuelta Tachira. Nel 2018 il Team ha debuttato nel migliore dei modi vincendo 4 Tappe alla Vuelta Tachira in Venezuela e inserendosi tra i protagonisti delle competizioni Europee, con il maggior numero di successi nella categoria Professional. Grande performance al Giro con più di 30 ore di diretta tv nelle varie fughe e coronando il finale con il podio a Roma. Vittoria importante: la nuova classica Adriatica Ionica con il giovane talento Colombiano Ivan Sosa. Nel 2019 il Team ha riconfermato il primato nella sua categoria, con più di venti vittorie stagionali, tra cui una vittoria di tappa al 102esimo Giro d'Italia con Fausto Masnada, e più di cinquanta podi in tre continenti. Durante il Giro d'Italia il team ha vinto anche due classifiche speciali: Combattività e Traguardi Volanti sempre con Fausto Masnada, che ha vinto anche la Cima Coppi. Questo ha portato l'Androni ad essere il team più in vista durante le 2700 ore di diretta televisiva in 194 paesi del mondo.

PALMARES

17 times to the Giro d'Italia, 14 stages victories.

1 Italian Championship, 1 Australian Championship, 5 Colombian Championship, 1 in Ireland, 3 in Switzerland, Romania and Venezuela. In 2017 the team used the Bottecchia bikes and achieved 100 podiums, including 25 victories in official UCI International races, such as the Tour of Slovakia, the Tour of Bihor and one stage of the Vuelta Tachira. In 2018 the Team started in the best way, winning 4 stages of the Vuelta Tachira in Venezuela, and becoming one of the protagonist of the European competitions. During the month of May it confirms its ability riding a big Giro, with more than 30 hours of TV live showing the athletes and the breakaways and the final podium in Rome, obtaining the classifications of the combativeness and the breakaways. An important Italian victory is the new classic race Adriatica Ionica, with the new Colombian talent Ivan Sosa. In 2019 the team reconfirmed its leadership in its category, with more than twenty seasonal victories, including a stage victory at the 102nd Giro d'Italia with Fausto Masnada, and more than fifty podiums on three continents. During the Giro d'Italia the team also won two special rankings: Fighting Spirit and Traguardi Volanti always with Fausto Masnada, who also won the Cima Coppi. This led Androni to be the most prominent team during the 2,700 hours of live television broadcasting in 194 countries around the world.

CORSA

EMME4 SQUADRA

LA BICI CAMPIONE D'ITALIA
THE ITALIAN CHAMPION BIKE



TELAIO CERTIFICATO UCI
UCI CERTIFIED FRAME

MONOLITH
TECHNOLOGY

73T EMME4 SQUADRA
SHIMANO DURA ACE Di2 22s

PESO / WEIGHT
6,530 Kg taglia M / size M

COLORE / COLOUR
cA1 SQUADRA



780 gr PESO/WEIGHT

0 PUNTI DI GIUNZIONE DEL TELAIO
FRAME JUNCTION POINTS

1 UNICO STAMPO MONOLITH
UNIQUE MONOLITH MOLD

2 SISTEMI DI ASSEMBLAGGIO FRENI: DISCO E CALIPER
BRAKE ASSEMBLY SYSTEMS: DISK AND CALIPER

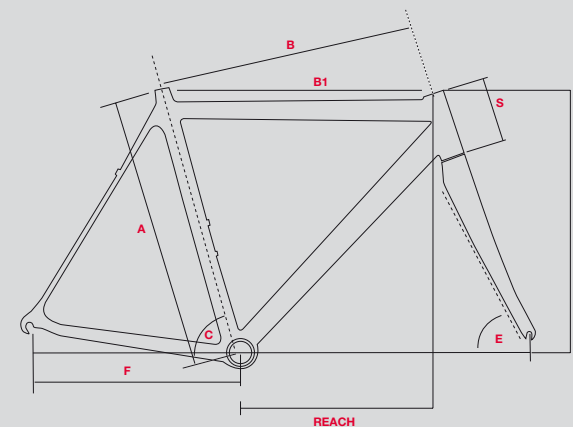

SIZE	A	B	B1	C	E	F	S	STACK	REACH
44	440	503	520	74,5°	71,5°	410	115	511	377
47	470	523	540	73,5°	72,5°	410	135	534	382
51	510	540	555	73°	73°	410	155	555	385
54	540	558	570	73°	73°	410	170	570	395
57	570	583	590	72,5°	73°	410	190	589	404

KT 73 EMME4 SUPERLIGHT

TELAIO / FRAME

Carbonio full monoscocca MONOLITH, forcellini intercambiabili in alu, predisposto per freni caliper o disco, gruppo meccanico o elettronico.

Full monocoque carbon, MONOLITH, alloy interchangeable dropouts, suitable for caliper or disk brakes, mechanic or electronic group set.

MOVIMENTO / BB

Pressfit 86

STERZO / HEADTUBE

Integrato 1" 1/8 sopra e 1" 1/2 sotto
integrated 1" 1/8 up and 1" 1/2 down

FORCELLA / FORK

Carbonio monoscocca super light con canotto conico 1"1/2 peso 330g

Monocoque carbon super light tapered steerer 1" 1/2 330g weight

COLORI / COLOURS

c58 Red Lab, cA1 Squadra, cA1 Custom, c21 Prisma, cA2 Camaleonte

PESO / WEIGHT

Taglia M grezzo 780g

Size M raw 780g

EMME4 SUPERLIGHT

Lasciati guidare dalle emozioni, al resto pensiamo noi

EMME 4 Superlight racchiude tutta l'esperienza e la tradizione del Reparto Corse e del laboratorio Red Lab, concentrate in un unico, straordinario telaio. Realizzato con la tecnologia Monolith, che permette di avere un vero unico monoscocca in totale assenza di punti di giunzione, questo telaio leggero e super performante si posiziona al top della sua categoria. Questa speciale tecnologia di produzione, attraverso la particolare configurazione dello stampo, consente il corretto e omogeneo posizionamento di tutti gli strati di carbonio su tutta la lunghezza del telaio, massimizzando elasticità e reattività. Il carro posteriore essendo un tutt'uno con il resto del telaio, assorbe vibrazioni ed asperità in modo unico, massimizzando rigidità e confort anche sulle lunghe distanze.



TELAIO CERTIFICATO UCI
UCI CERTIFIED FRAME

MONOLITH
TECHNOLOGY

73S EMME4 SUPERLIGHT
SHIMANO DURA ACE 22s

PESO / WEIGHT
6,650 Kg taglia M / size M

COLORE / COLOUR
c58 Red Lab

RED+
LAB

Let yourself be guided by emotions, we'll take care of the rest

EMME 4 Superlight embodies all the experience and tradition of the Reparto Corse Department and the Red Lab laboratory, concentrated in a single, extraordinary frame. Made with the Monolith technology, which allows to have a truly unique monocoque in the total absence of junction points, this lightweight and high-performance frame is positioned at the top of its category. This special production technology, through the particular configuration of the mold, allows the correct and homogeneous positioning of all the carbon layers over the entire length of the frame, maximizing elasticity and reactivity. The rear stay being one with the rest of the frame, absorbs vibrations and asperities in a unique way, maximizing rigidity and comfort even over long distances.



TOP PRO



PRO



AMATEUR



LIGHTWEIGHT



STIFFNESS



AEREO



COMFORT



73LD EMME4 SUPERLIGHT
CAMPAGNOLO SUPER RECORD DISK 24s

PESO / WEIGHT
 6,950 Kg taglia M / size M

COLORE / COLOUR
 cA1 Rosso Nero / cA1 Red Black



73X EMME4 SUPERLIGHT
SHIMANO DURA ACE DISK 22s

PESO / WEIGHT
 7,450 Kg taglia M / size M

COLORE / COLOUR
 cA1 Bianco Nero / cA1 White Black

73X EMME4 SUPERLIGHT
SHIMANO DURA ACE DISK 22s

PESO / WEIGHT
 7,450 Kg taglia M / size M

COLORE / COLOUR
 cA1 Grigio Nero
 cA1 Grey Black



73S EMME4 SUPERLIGHT
SHIMANO DURA ACE 22s

PESO / WEIGHT
 6,650 Kg taglia M / size M

COLORE / COLOUR
 cA1 Azzurro Nero
 cA1 Light Blue Black



73Q EMME4 SUPERLIGHT
SHIMANO ULTEGRA 22s

PESO / WEIGHT
 7,720 Kg taglia M / size M

COLORE / COLOUR
 cA1 Rosa Nero
 cA1 Pink Black



CORSA

EMME4 SUPERLIGHT

73A EMME4 SUPERLIGHT

SRAM RED eTap AXS DISK 24s

PESO / WEIGHT

7,030 Kg taglia M / size M

COLORE / COLOUR

c21 Prisma



PRISMA

Nuova colorazione nero opaca con grafica prismatica lucida. I sette colori fondamentali si compongono per creare un effetto arcobaleno quando colpiti dalla luce.

New matt black colour with glossy prismatic graphics. The seven basic colours are composed to create a rainbow effect when struck by light.

ALLESTIMENTI / EQUIPMENTS

73LD	EMME 4 SUPERLIGHT Campagnolo Super Record DISK 24s
73GD	EMME 4 SUPERLIGHT Campagnolo Chorus DISK 24s
73A	EMME 4 SUPERLIGHT Sram Red eTap AXS DISK 24s
73F	EMME 4 SUPERLIGHT Sram Force eTap AXS DISK 24s
73TD	EMME 4 SUPERLIGHT Shimano Dura Ace Di2 DISK 22s
73X	EMME 4 SUPERLIGHT Shimano Dura Ace DISK 22s
73S	EMME 4 SUPERLIGHT Shimano Dura Ace 22s
73RD	EMME 4 SUPERLIGHT Shimano Ultegra Di2 DISK 22s
73Y	EMME 4 SUPERLIGHT Shimano Ultegra DISK 22s
73Q	EMME 4 SUPERLIGHT Shimano Ultegra 22s

CAMALEONTE

Nuova colorazione ad effetto cangiante.
Il colore "si muove" con il riflesso della luce cambiando tonalità.

New colour with iridescent effect.
The colour "moves" with the reflection of light changing hues.

73F EMME4 SUPERLIGHT SRAM FORCE eTap AXS DISK 24s

PESO / WEIGHT

7,630 Kg taglia M / size M

COLORE / COLOUR

cA2 Camaleonte



AEROSPACE

ORO / GOLD

Nuova colorazione nero opaca con grafica laminata oro lucida.

New matt black colour with glossy gold laminated graphic.

65F AEROSPACE

SRAM FORCE eTap AXS DISK 24s

PESO / WEIGHT

8,025 Kg taglia M / size M

COLORE / COLOUR

c84 Nero Oro
c84 Black Gold

ALLESTIMENTI / EQUIPMENTS

65LD	AEROSPACE Campagnolo Super Record DISK 24s
65GD	AEROSPACE Campagnolo Chorus DISK 24s
65A	AEROSPACE Sram Red eTap AXS DISK 24s
65F	AEROSPACE Sram Force eTap AXS DISK 24s
65TD	AEROSPACE Shimano Dura Ace Di2 DISK 22s
65X	AEROSPACE Shimano Dura Ace DISK 22s
65RD	AEROSPACE Shimano Ultegra Di2 DISK 22s
65Y	AEROSPACE Shimano Ultegra DISK 22s
65D	AEROSPACE Shimano 105 DISK 22s



La velocità ha un nuovo nome

Ci siamo spinti oltre ogni limite per tradurre il concetto assoluto di aerodinamicità in numeri e forme per renderti più veloce. AEROSPACE è la nuova aerobike da strada ultra veloce con freni a disco Flat Mount e tecnologia Internal Routing Cables con cavi totalmente integrati nel telaio. Dietro al design pulito e inconfondibilmente made in Italy si sviluppano i concetti di velocità, integrazione e stabilità per garantire il massimo controllo di guida anche alle alte velocità. La totale assenza di cavi esterni massimizza l'efficienza aerodinamica e lascia invariata l'eleganza e la precisione del design. Il nuovo telaio aerocarbon assorbe le vibrazioni in corsa e le trasforma in velocità, grazie alle geometrie high performance e alla particolare conformazione dei tubi. Perfetta per le fughe in solitaria e gli sprint al traguardo, compatibile con tutti i gruppi meccanici e elettronici, la nuova AEROSPACE è la nuova forma della velocità su strada.

65RD AEROSPACE

SHIMANO ULTEGRA Di2 DISK 22s

PESO / WEIGHT

7,945 Kg taglia M / size M

COLORE / COLOUR

C58 Red Lab



Speed has a new name

We have gone beyond all limits to translate the absolute concept of aerodynamics into numbers and shapes to make you faster. AEROSPACE is the new ultra-fast road aerobike with Flat Mount disc brakes and Internal Routing Cables technology with fully integrated cables into the frame. Behind the clean and unmistakably made in Italy design, the concepts of speed, integration and stability are developed to guarantee maximum riding control even at high speeds. The total absence of external cables maximizes aerodynamic efficiency and leaves the elegance and precision of design unchanged. The new aerocarbon frame absorbs vibrations when riding and transforms them into speed, thanks to the high performance geometries and the particular conformation of the tubes. Perfect for solo escapes and sprints at the finish line, compatible with all mechanical and electronic groups, the new AEROSPACE is the new form of road speed.

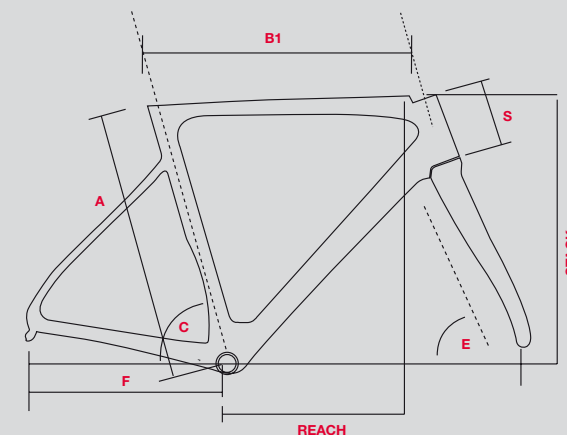

SIZE	A	B1	C	E	F	S	STACK	REACH
47	470	505	74,5°	71,5°	408	95	505	365
49	490	515	74,5°	71,5°	408	105	515	372
51	510	530	74°	72°	408	108	517	382
53	530	550	74°	72°	408	130	538	396
55	550	565	73,5°	72,5°	408	140	547	405
57	570	580	73°	72,5°	408	150	558	409

KT 65 AEROSPACE

TELAIO / FRAME

Carbonio monoscocca Aero, freni a disco perni passanti, reggisella Aero, passaggio cavi full integrato.

Monocoque carbon Aero, disk brakes thru axle, Aero seatpost, internal routing cables.

MOVIMENTO / BB

Pressfit 86

STERZO / HEADTUBE

Integrato 1" 1/2 sopra e 1" 1/2 sotto
integrated 1" 1/2 up and 1" 1/2 down

FORCELLA / FORK

Carbonio monoscocca con canotto conico 1"1/2 peso 445g.
Monocoque carbon tapered steerer 1" 1/2, 445g weight.

COLORI / COLOURS

c58 Red Lab, c21 Prisma, c84 Nero Oro / c84 Black Gold

PESO / WEIGHT

Taglia M grezzo 1125g
Size M row 1125g

CORSA

AEROSPACE

65A AEROSPACE

SRAM RED eTap AXS DISK 24s

PESO / WEIGHT

7,550 Kg taglia M / size M

COLORE / COLOUR

c21 Prisma



TOP PRO

100%

**PRO**

90%

**AMATEUR**

40%

**LIGHTWEIGHT**

70%

**STIFFNESS**

80%

**AEREO**

100%

**COMFORT**

70%

**PRISMA**

Nuova colorazione nero opaca con grafica prismatica lucida. I sette colori fondamentali si compongono per creare un effetto arcobaleno quando colpiti dalla luce.

New matt black colour with glossy prismatic graphics. The seven basic colours are composed to create a rainbow effect when struck by light.



T2 DOPPIA CORSA

TOP PRO



PRO



AMATEUR



LIGHTWEIGHT



STIFFNESS



AEREO



COMFORT



ALLESTIMENTI / EQUIPMENTS

- 67LD T2 DOPPIA CORSA Campagnolo Super Record DISK 24s
- 67GD T2 DOPPIA CORSA Campagnolo Chorus DISK 24s
- 67A T2 DOPPIA CORSA Sram Red eTap AXS DISK 24s
- 67F T2 DOPPIA CORSA Sram Force eTap AXS DISK 24s
- 67TD T2 DOPPIA CORSA Shimano Dura Ace Di2 DISK 22s
- 67X T2 DOPPIA CORSA Shimano Dura Ace DISK 22s
- 67S T2 DOPPIA CORSA Shimano Dura Ace 22s
- 67RD T2 DOPPIA CORSA Shimano Ultegra Di2 DISK 22s
- 67Y T2 DOPPIA CORSA Shimano Ultegra DISK 22s
- 67Q T2 DOPPIA CORSA Shimano Ultegra 22s

67S T2 DOPPIA CORSA
SHIMANO DURA ACE 22s

PESO / WEIGHT
 6,950 Kg taglia M / size M

COLORE / COLOUR
 c58 Red Lab



TELAIO CERTIFICATO UCI
 UCI CERTIFIED FRAME



Monoscocca multiperformance disegnata e progettata in italia

Questo telaio, nasce dall'unione dei principi aerodinamici propri dei telai crono e le caratteristiche di quelli da strada con attitudini da salita. Il design studiato conferisce a T2 straordinarie doti velocistiche e caratteristiche tecniche proprie dei telai in carbonio più performanti. L'innovativo sistema Multi Performance Brakes permette di predisporre e assemblare il telaio corsa sia con freni a Disco Flat Mount che Caliper Direct Mount. La forcella integrata dedicata in versione disco con perno passante e versione caliper con quick release, testa da 1" e mezzo e foderi dritti, ne conferiscono stabilità e rigidità uniche.

Monocoque multiperformance engineered and designed in Italy

This frame is born from the union of the aerodynamic principles of the chrono frames and the characteristics of the road ones with uphill aptitudes. The studied design gives T2 extraordinary speed qualities and technical characteristics of the best performing carbon frames. The innovative Multi Performance Brakes system allows you to set up and assemble the racing frame with both Flat Mount and Caliper Direct Mount disc brakes. The dedicated integrated fork in the disc version with through axle and the caliper version with quick release, 1" and a half headset and straight prongs, give it unique stability and rigidity.

67Y T2 DOPPIA CORSA SHIMANO ULTEGRA DISK 22s

PESO / WEIGHT
8,400 Kg taglia M / size M

COLORE / COLOUR
c11 Nero Grigio Opaco
c11 Matt Black Grey



OPZIONE / OPTION
RUOTE FULCRUM WIND 400 CARBON DISK
FULCRUM WIND 400 CARBON DISK WHEELS

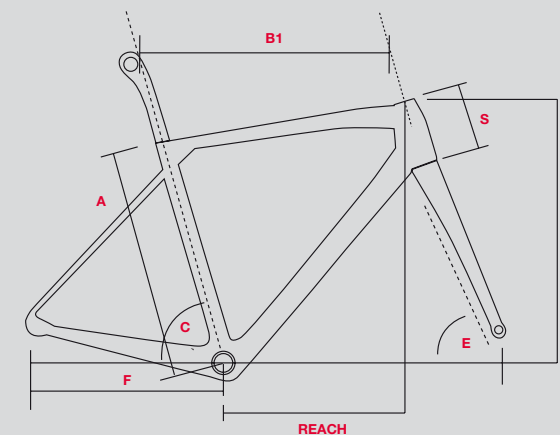

SIZE	A	B1	C	E	F	S	STACK	REACH
44	440	520	74,5°	71,5°	410	115	511	377
47	470	540	73,5°	72,5°	410	135	534	382
51	510	555	73°	73°	410	155	554	385
54	540	570	73°	73°	410	170	569	395
57	570	585	72,5°	73,5°	410	190	590	403

KT 67 T2 DOPPIA CORSA

TELAIO / FRAME

Carbonio monoscocca UD, compatibile per freni a montaggio diretto doppio perno e per freni a disco. Reggisella aero, forcellini intercambiabili.

Monocoque carbon UD, suitable for direct mount double pivot brakes and for disk brake. Aero seatpost, interchangeable dropouts.

MOVIMENTO / BB

Pressfit 86

STERZO / HEADTUBE

Integrato 1" 1/8 sopra e 1" 1/2 sotto
integrated 1" 1/8 up and 1" 1/2 down

FORCELLA / FORK

Carbonio monoscocca UD super light con canotto conico 1"1/2 peso 360g
Monocoque carbon UD super light tapered steerer 1" 1/2 360g weight

COLORI / COLOURS

c58 Red Lab, c11 Nero Grigio Opaco / c11 Matt Black Grey

PESO / WEIGHT

Taglia M grezzo 1200g con reggisella
Size M raw 1200g with seatpost

T1 ENDURANCE

66S T1 ENDURANCE
SHIMANO DURA ACE 22S

PESO / WEIGHT
 7,280 Kg taglia M / size M

COLORE / COLOUR
 c29 Rosso Nero
 c29 Red Black

ALLESTIMENTI / EQUIPMENTS

66L	T1 ENDURANCE Campagnolo Super Record 24s
66V	T1 ENDURANCE Campagnolo Potenza 22s
66C	T1 ENDURANCE Campagnolo Centaur 22s
66T	T1 ENDURANCE Shimano Dura Ace Di2 22s
66S	T1 ENDURANCE Shimano Dura Ace 22s
66R	T1 ENDURANCE Shimano Ultegra Di2 22s
66Q	T1 ENDURANCE Shimano Ultegra 22s
66P	T1 ENDURANCE Shimano 105 / Ultegra Mix 22s
66O	T1 ENDURANCE Shimano 105 22s



OPZIONE / OPTION
 RUOTE FULCRUM RACING 4 CARBON CLINCHER.
 FULCRUM RACING 4 CARBON CLINCHER WHEELS.

RED LAB



TELAIO CERTIFICATO UCI
UCI CERTIFIED FRAME

TOP PRO



PRO



AMATEUR



LIGHTWEIGHT



STIFFNESS



AEREO



COMFORT



66S T1 ENDURANCE SHIMANO DURA ACE 22S

PESO / WEIGHT
7,280 Kg taglia M / size M

COLORE / COLOUR
c93 Nero Verde
c93 Black Green



OPZIONE / OPTION
RUOTE FULCRUM RACING 4 CARBON CLINCHER.
FULCRUM RACING 4 CARBON CLINCHER WHEELS.

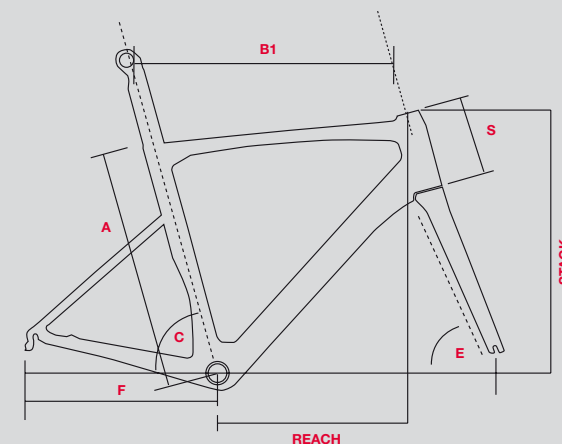

SIZE	A	B1	C	E	F	S	STACK	REACH
47	470	516	75,5°	72,5°	405	100	513	383
51	510	531	75°	73,5°	405	130	535	388
53	530	542	74,5°	73,5°	405	150	554	388
55	550	560	73,5°	73°	405	170	571	391
57	570	576	73°	73°	405	200	600	393
59	590	595	73°	74°	405	220	623	405

KT 66 T1 ENDURANCE

TELAIO / FRAME

Carbonio monoscocca Super Aero, freni a montaggio diretto doppio perno, reggisella aero.
Monocoque carbon Super Aero, direct mount double pivot brakes, Aero seatpost.

MOVIMENTO / BB

Pressfit 86

STERZO / HEADTUBE

Integrato 1" 1/8 sopra e 1" 1/2 sotto
integrated 1" 1/8 up and 1" 1/2 down

FORCELLA / FORK

Carbonio monoscocca 1k super light con canotto conico 1"1/2 peso 410g
Monocoque carbon 1k super rlight tapered steerer 1" 1/2 410g weight

COLORI / COLOURS

c58 Red lab, c93 Nero Verde / c93 Black Green

PESO / WEIGHT

Taglia M grezzo 1050g
Size M raw 1050g

8AVIO REVOLUTION

ALLESTIMENTI / EQUIPMENTS

57GD	8AVIO REVOLUTION Campagnolo Chorus DISK 24s	57Y	8AVIO REVOLUTION Shimano Ultegra DISK 22s
57C	8AVIO REVOLUTION Campagnolo Centaur 22s	57Q	8AVIO REVOLUTION Shimano Ultegra 22s
57F	8AVIO REVOLUTION Sram Force eTap AXS DISK 24s	57D	8AVIO REVOLUTION Shimano 105 DISK 22s
57TD	8AVIO REVOLUTION Shimano Dura Ace Di2 DISK 22s	57O	8AVIO REVOLUTION Shimano 105 22s
57X	8AVIO REVOLUTION Shimano Dura Ace DISK 22s	57P	8AVIO REVOLUTION Shimano 105/Ultegra Mix 22s
57S	8AVIO REVOLUTION Shimano Dura Ace 22s	57W	8AVIO REVOLUTION Shimano Tiagra Mix 20V
57RD	8AVIO REVOLUTION Shimano Ultegra Di2 DISK 22s	57J	8AVIO REVOLUTION Shimano Tiagra Mix DISK 20s
57R	8AVIO REVOLUTION Shimano Ultegra Di2 22s		

TOP PRO



PRO



AMATEUR



LIGHTWEIGHT



STIFFNESS



AEREO



COMFORT



57GD **8AVIO REVOLUTION**
CAMPAGNOLO CHORUS DISK 24s

PESO / WEIGHT

8,350 Kg taglia M / size M

COLORE / COLOUR

c81 Nero Rosso
c81 Black Red

57P SAVIO REVOLUTION
SHIMANO 105/ULTEGRA MIX 22s

PESO / WEIGHT
 8,850 Kg taglia M / size M

COLORE / COLOUR
 c93 Verde Nero
 c93 Green Black

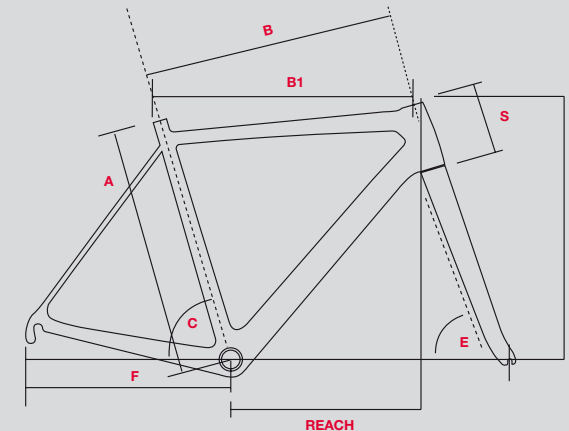

SIZE	A	B	B1	C	E	F	S	STACK	REACH
43	430	475	491	75,5°	70,5°	405	100	495	363
48	480	499	515	75,5°	71,5°	405	110	508	384
51	510	517	535	74,5°	72,5°	405	125	525	389
54	540	531	555	73,5°	73,5°	405	145	548	393
58	580	569	585	72,5°	73,5°	405	185	586	400

57D SAVIO REVOLUTION
SHIMANO 105 DISK 22s

PESO / WEIGHT
 8,500 Kg taglia M / size M

COLORE / COLOUR
 c64 Azzurro Nero
 c64 Light Blue Black



KT 57 SAVIO REVOLUTION

TELAIO / FRAME

Carbonio UD monoscocca, doppio stampo, cavi interni, compatibile per freni caliper e per freni a disco.
 UD carbon monocoque, double mold, internal cable routing, suitable both for caliper brakes and for disk brakes.

MOVIMENTO / BB

Pressfit 86

STERZO / HEADTUBE

Integrato 1" 1/8 sopra e 1" 1/2 sotto
 Integrated 1" 1/8 up and 1" 1/2 down

FORCELLA / FORK

Carbonio monoscocca UD con canotto conico 1" 1/2 peso 450g
 Monocoque carbon UD tapered steerer 1" 1/2 450g weight

COLORI / COLOURS

c81 Nero Rosso, c93 Verde Nero, c64 Azzurro Nero
 c81 Black Red, c93 Green Black, c64 Light Blue Black

PESO / WEIGHT

Taglia M grezzo 1120g
 Size M raw 1120g

77S CRONOTHLON

SHIMANO DURA ACE 22s

PESO / WEIGHT

8,100 Kg taglia M / size M

COLORE / COLOUR

c58 Red Lab



CRONOTHLON

ALLESTIMENTI / EQUIPMENTS

77S	CRONOTHLON Shimano Dura Ace 22s
77R	CRONOTHLON Shimano Ultegra Di2 22s
77Q	CRONOTHLON Shimano Ultegra 22s

TOP PRO

100%



PRO

100%



AMATEUR

40%



LIGHTWEIGHT

90%



STIFFNESS

100%



AEREO

100%



COMFORT

80%



RED
LAB



TELAIO CERTIFICATO UCI
UCI CERTIFIED FRAME

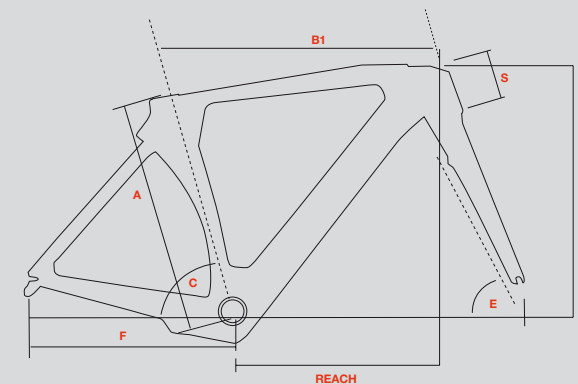

SIZE	A	B1	C	E	F	S	STACK	REACH
49	450	490	75°	71°	395	91,5	453	372,5
51	530	512	75°	72,5°	395	101,5	512	378
53	540	533	75°	72,5°	395	111,5	521	396
55	557	552	75°	72,5°	395	129,5	538	410
57	576	570	75°	72,5°	395	148	556	424

KT 77 CRONOTHLON

TELAIO / FRAME

Carbonio UD monoscocca con manubrio monoscocca integrato freni integrati e reggisella.

UD monocoque carbon with integrated handlebar, stem brakes and seatpost.

MOVIMENTO / BB

BSA 68mm

STERZO / HEADTUBE

Integrato 1" 1/8 sopra e 1" 1/2 sotto

integrated 1" 1/8 up and 1" 1/2 down

FORCELLA / FORK

Carbonio monoscocca UD con freni integrati peso 430g

UD monocoque carbon with integrated brakes 430g weight

COLORI / COLOURS

c58 Red Lab

PESO / WEIGHT

Taglia M grezzo 1420 g

Size M raw 1420 g

LEGGENDARIA

Bottecchia

Versione Saronni
Replica Team SCIC
Vincitore Giro d'Italia
1979

Saronni Replica
Team SCIC version
Winner of Giro
d'Italia 1979



ALLESTIMENTI / EQUIPMENTS

40V LEGGENDARIA Campagnolo Potenza 22s
40C LEGGENDARIA Campagnolo Centaur 22s

COLORE / COLOUR
c35 Rosso Bianco
c35 Red White



40V **LEGGENDARIA**
CAMPAGNOLO POTENZA 22s

PESO / WEIGHT
9,600 Kg taglia 54 / size 54

COLORE / COLOUR
 c10 Bianco Nero opaco
 c10 Matt White Black



COLORE / COLOUR
 c15 Bianco Blu
 c15 White Blue

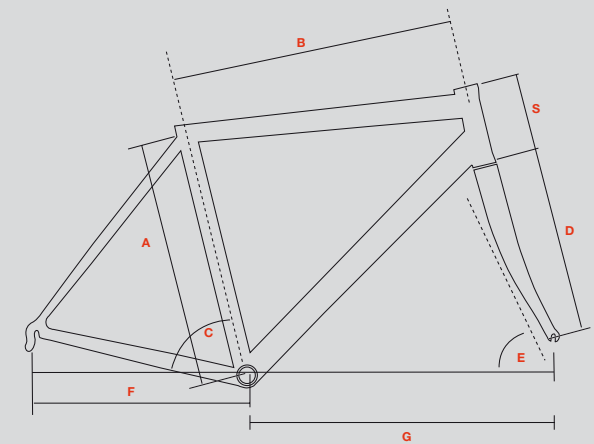

SIZE	A*	B	C	D	E	F	G	S
47	470	495	75°	363	70°	398	568	85
48	480	510	74.5°	363	72°	401	557	85
49	490	515	74.5°	363	72°	402	571	95
50	500	520	74.5°	363	72.5°	402	573	97
51	510	525	74°	363	72.5°	402	573.2	104
52	520	535	74°	363	72.5°	403	583	113
53	530	540	73°	363	73°	405	579	120
54	540	545	73.5°	363	73°	405	579.2	135
55	550	550	73.5°	363	73°	405	584	139
56	560	560	73.5°	363	73°	405	594	146
57	570	565	73.5°	363	73°	405	584	159
58	580	570	73°	363	73°	407	599.5	167
59	590	575	73°	363	73°	408	604	178
60	600	580	73°	363	73°	409	609	186
61	610	580	73°	363	73°	409	609	188
62	620	590	73°	363	73°	409	619	199
63	630	590	73°	363	73°	410	619	216
64	640	595	73.5°	363	74°	410	620	224

* La misura A è centro Movimento centro tubo orizzontale
 * The size A is middle BB to middle top tube.

KT 40 LEGGENDARIA

TELAIO / FRAME

Acciaio COLUMBUS 3 tubi Spirit
 COLUMBUS 3 steel tubes Spirit

MOVIMENTO / BB

BSA 68 mm

STERZO / HEADTUBE

A congiunzioni 1"
 With lug 1"

FORCELLA / FORK

Acciaio COLUMBUS Cromor a congiunzioni peso 650 g
 COLUMBUS Cromor steel with lug 650 g weight

COLORI / COLOURS

c10 Bianco Nero Opaco, c15 Bianco Blu, c35 Rosso Bianco
 c10 Matt White Black, c15 Blue White, c35 Red White

PESO / WEIGHT

Taglia M grezzo 1750g
 Size M raw 1750g

DUELLO

53J DUELLO DISK
SHIMANO TIAGRA MIX DISK 20s

PESO / WEIGHT
10,790 Kg taglia M / size M

COLORE / COLOUR
c64 Azzurro Nero
c64 Light Blue Black

ALLESTIMENTI / EQUIPMENTS

- 54N DUELLO Shimano 105 Mix 22s
- 54B DUELLO Campagnolo Veloce Mix 20s
- 54U DUELLO Shimano Sora Mix 18s
- 54K DUELLO Shimano Claris Mix 16s
- 53J DUELLO Shimano Tiagra Mix DISK 20s



54B DUELLO

CAMPAGNOLO VELOCE MIX 20s

PESO / WEIGHT

10,720 Kg taglia M / size M

COLORE / COLOUR

c59 Antracite Verde Opaco

c59 Matt Anthracite Green

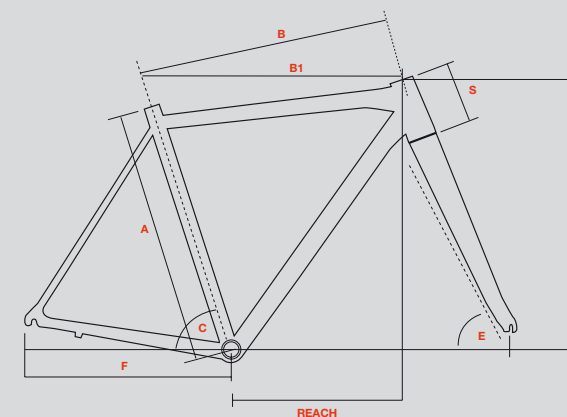

SIZE	A	B	B1	C	E	F	S	STACK	REACH
44	440	501	515	74,5°	71°	405	120	513	372
48	480	520	530	74°	72°	405	120	517	382
51	510	534	545	73,5°	73°	405	140	540	385
54	540	545	555	73,5°	73,5°	405	160	560	389
57	570	571	580	72,5°	73°	405	180	578	398
60	600	598	600	72,5°	74°	405	180	578	417

KT 53 / KT 54 DUELLO

TELAIO / FRAME

DUELLO Alu 6061 doppio spessore compatibile per l'assemblaggio di freni a disco o caliper.

DUELLO Alu 6061 double thickness suitable for the assembly of disk or caliper brakes.

MOVIMENTO / BB

BSA 68mm

STERZO / HEADTUBE

Integrato 1" 1/8 sopra e 1" 1/2 sotto
integrated 1" 1/8 up and 1" 1/2 down

FORCELLA / FORK

Carbonio con canotto alu conico 1"1/2 peso 610g
Carbon with alu tapered steerer 1"1/2 610g weight

COLORI / COLOURS

c64 Azzurro Nero, c81 Rosso Nero, c59 Antracite Verde Opaco
c64 Light Blue Black, c81 Red Black, c59 Matt Anthracite Green

PESO / WEIGHT

Taglia M grezzo 1310g

Size M row 1310g



54N DUELLO

SHIMANO 105 MIX 22s

PESO / WEIGHT

10,490 Kg taglia M / size M

COLORE / COLOUR

c81 Rosso Nero / c81 Red Black

ZOLDER CROSS

461 ZOLDER CROSS
SHIMANO 105 / ULTEGRA MIX DISK 22S

PESO / WEIGHT
 9,300 Kg taglia M / size M

COLORE / COLOUR
 c38 Nero Giallo Fluo Opaco
 c38 Matt Black Yellow Fluo

TOP PRO

80%



PRO

90%



AMATEUR

100%



LIGHTWEIGHT

90%



STIFFNESS

80%



AEREO

70%



COMFORT

90%

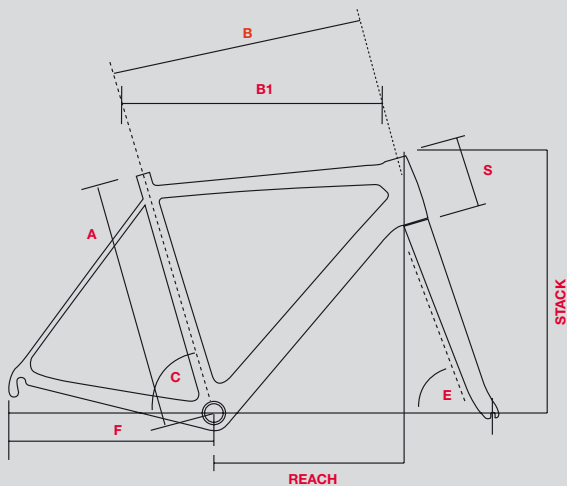

SIZE	A	B	B1	C	E	F	S	STACK	REACH
48	480	501	510	74,5°	70,50°	425	100	510	378
52	520	525	535	74,5°	71°	425	125	537	385
54	540	535	545	74°	71°	425	135	548	387
58	580	565	575	73,5°	72°	425	160	578	398

KT 46 ZOLDER

TELAIO / FRAME

Cross Carbonio monoscocca UD, freni a disco, perno passante da 12mm.

Monocoque carbon UD, disk brakes flat mount, thru axle 12mm.

MOVIMENTO / BB

BSA

STERZO / HEADTUBE

Integrato 1" 1/8 sopra e 1" 1/2 sotto

integrated 1" 1/8 up and 1" 1/2 down

FORCELLA / FORK

Carbonio monoscocca light con canotto conico 1"1/2

peso 390g perno passante da 12mm

Monocoque carbon light tapered steerer 1" 1/2 390g weight thru

axle 12mm

COLORI / COLOURS

c38 Nero Giallo Fluo Opaco

c38 Matt Black Yellow Fluo

PESO / WEIGHT

Taglia M grezzo 1080g

Size M raw 1080g



CORSA

LIEGI CROSS

45N **LIEGI CROSS**
SHIMANO 105 MIX DISK 22S

PESO / WEIGHT
10,300 Kg taglia M / size M

COLORE / COLOUR
c33 Verde Fluo
c33 Green Fluo

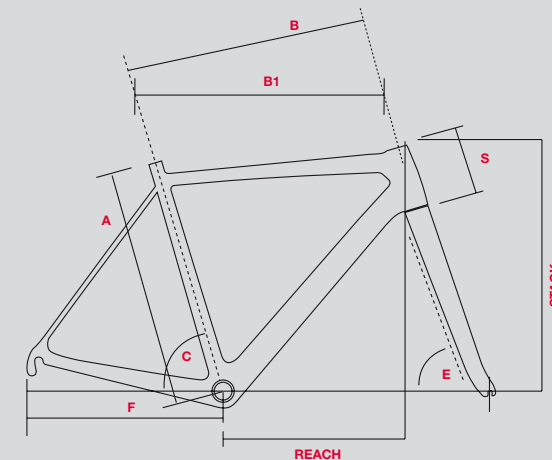

SIZE	A	B	B1	C	E	F	S	STACK	REACH
48	480	501	510	75.5°	70.5°	425	100	509	378
52	520	525	535	74.5°	71°	425	125	536	525
54	540	535	545	74°	71.5°	425	135	548	535
58	580	565	575	73°	72.5°	425	160	577	398

KT 45 LIEGI

TELAIO / FRAME

Cross Alu 6061 doppio spessore, freni a disco
Cross Alu 6061 double butted, disk brakes

MOVIMENTO / BB

BSA

STERZO / HEADTUBE

Integrato 1" 1/8 sopra e 1" 1/2 sotto
integrated 1" 1/8 up and 1" 1/2 down

FORCELLA / FORK

Alu 6061 doppio spessore light con canotto conico 1"1/2
peso 800g
Alu 6061 double butted light tapered steerer 1"1/2 800g weight

COLORI / COLOURS

c33 Verde Fluo
c33 Green Fluo

PESO / WEIGHT

Taglia M grezzo 1390g
Size M row 1390g

49Y GRAVEL CARBON
SHIMANO ULTEGRA DISK 22s

PESO / WEIGHT
9,660 Kg taglia M / size M

COLORE / COLOUR
c86 Antracite Azzurro Opaco
c86 Matt Anthracite Light Blue



GRAVEL CARBON

ALLESTIMENTI / EQUIPMENTS

- 49Y GRAVEL CARBON Shimano Ultegra DISK 22s
- 49N GRAVEL CARBON Shimano 105 mix DISK 22s
- 49AP GRAVEL CARBON Sram Apex DISK 11s

Attitudine da strada, spirito da offroad

Quando non programmi il percorso e hai voglia di esplorare nuove strade, che tu sia su strade bianche, sterrati o asfalto, la nuova GRAVEL CARBON ti permetterà di affrontare qualsiasi terreno, in qualsiasi stagione.

Freni a disco, possibilità di montare pneumatici più larghi e geometrie comode la rendono affidabile in ogni situazione. Se cerchi una bici versatile, maneggevole e leggera, dalle straordinarie capacità, e che ti porti comodamente oltre il solito percorso su strada, hai trovato la bici giusta.

Road attitude, offroad spirit

When you don't plan the route and you want to explore new roads, whether you're on dirt roads or asphalt, the new GRAVEL CARBON will let you tackle any terrain, whatever season.

Disk brakes, possibility of fitting wider tires and comfortable geometries make it reliable in every situation. If you are looking for a versatile, manoeuvrable and light bike with extraordinary capabilities, and that will comfortably take you over the usual road route, you have found the right bike.

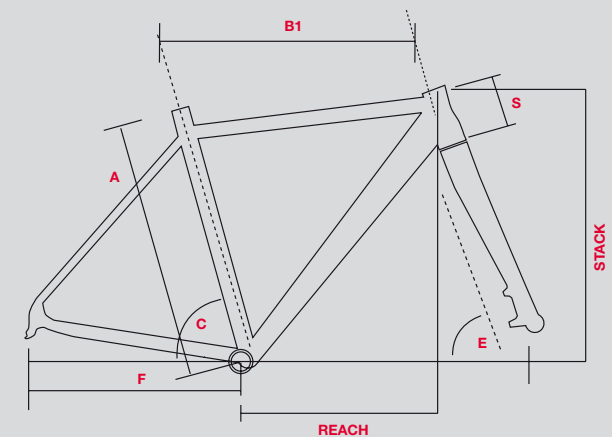

SIZE	A	B1	C	E	F	S	STACK	REACH
49	490	525	74,5°	70,5°	395	120	538	375
52	520	535	74°	71°	395	140	556	376
54	540	545	73,5°	71,5°	395	150	568	377
56	560	560	73°	72°	395	170	589	380
58	580	575	72,5°	72°	395	190	606	383

KT 49 GRAVEL CARBON

TELAIO / FRAME

Gravel Carbonio monoscocca UD disco, freni a disco, perno passante da 12mm.

Gravel Carbon monocoque UD disco, disk brakes, thru axle 12mm.

MOVIMENTO / BB

Pressfit 86

STERZO / HEADTUBE

Integrato 1" 1/8 sopra e 1" 1/2 sotto
integrated 1" 1/8 up and 1" 1/2 down

FORCELLA / FORK

Carbonio monoscocca con canotto conico 1"1/2 peso 510g
perno passante da 12mm.

Monocoque carbon tapered steerer 1" 1/2 510g weight thru axle 12mm.

COLORI / COLOURS

c86 Antracite Azzurro Opaco
c86 Matt Anthracite Light Blue

PESO / WEIGHT

Taglia M grezzo 1230g
Size M row 1230g

GRAVEL MONSTER

48AP GRAVEL MONSTER
SRAM APEX DISK 11s

PESO / WEIGHT
11,110 Kg taglia M / size M

COLORE / COLOUR
c06 Verde Opaco
c06 Matt Green



ALLESTIMENTI / EQUIPMENTS

- 48Y GRAVEL MONSTER Shimano Ultegra DISK 22s
- 48N GRAVEL MONSTER Shimano 105 mix DISK 22s
- 48AP GRAVEL MONSTER Sram Apex DISK 11s
- 48U GRAVEL MONSTER Shimano Sora mix DISK 18s

GRAVEL EXCLUSIVE SPORTSWEAR



COMPLETO GRAVEL/GRAVEL SUIT

ATGRA Maglia Gravel manica corta / Gravel T-shirt
ABGRA Pantaloncino Gravel / Gravel Shorts
Colore / Colour: Grigio Nero / Grey Black
Taglia / Size: S-M-L-XL-XXL

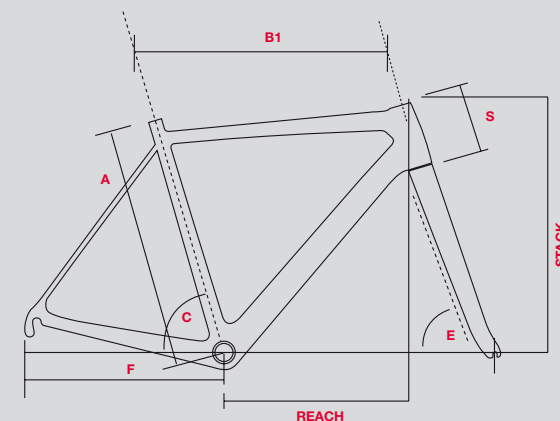

SIZE	A	B1	C	E	F	S	STACK	REACH
48	480	515	74,5°	70,5°	430	105	524	369
52	520	530	74,0°	71°	430	120	540	374
54	540	550	73,5°	71,5°	430	140	561	383
58	580	580	73°	72°	430	180	601	395

KT 48 GRAVEL

TELAIO / FRAME

Gravel Alu 6061 doppio spessore, freni a disco
Gravel Alu 6061 double butted, disk brake

MOVIMENTO / BB

BSA

STERZO / HEADTUBE

Integrato 1" 1/8 sopra e 1" 1/2 sotto
integrated 1" 1/8 up and 1" 1/2 down

FORCELLA / FORK

Alu 6061 double Butted light con cannotto conico 1"1/2 peso
800g

Alu 6061 double Butted light tapered steerer 1"1/2 800g weight

COLORI / COLOURS

c06 Verde Opaco

c06 Matt Green

PESO / WEIGHT

Taglia M grezzo 1460g

Size M raw 1460g



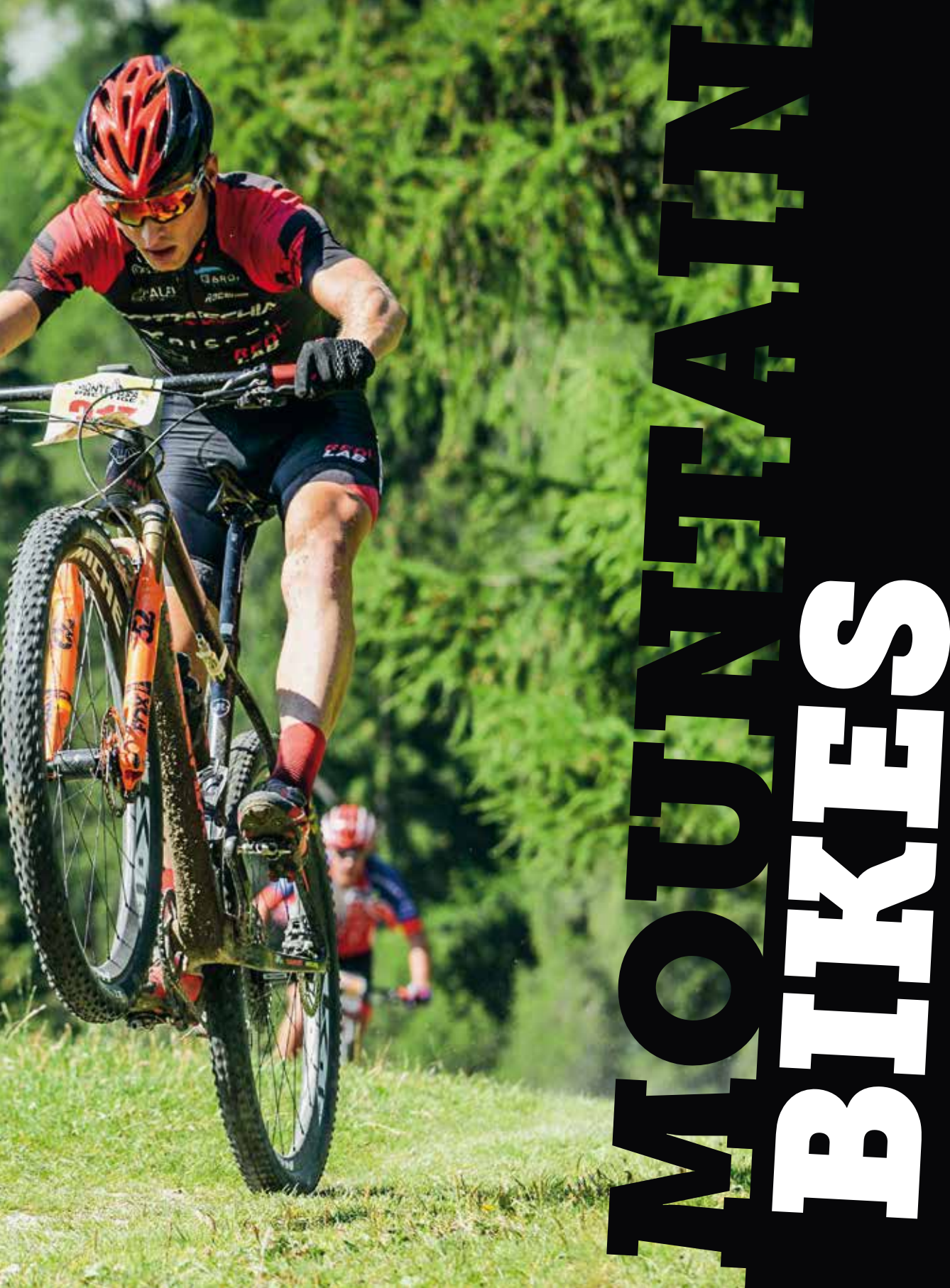

Sentieri, sterrati e salti. Pendii che lasciano senza respiro. Questi sono gli elementi perfetti su cui provare una mountain bike Bottecchia. Vi sentirete tutt'uno con il panorama e la natura, libererete il vostro spirito con una bella scarica di adrenalina.

Trails, dirt tracks and jumps. Slopes that leave you breathless. These are the perfect elements where testing a Bottecchia mountain bike. You will feel a unique thing with landscape and nature; you will free your spirit with a great adrenalin rush.

BOTTECCHIA FACTORY TEAM

Dal 2014 il BOTTECCHIA FACTORY TEAM, entra tra gli "UCI TEAM" e partecipa alle principali gare Nazionali e Internazionali di primaria importanza. Un team tutto Italiano che punta a emergere nel panorama internazionale grazie ad una formazione solida con grande esperienza. Stefano Dal Grande, Marcello Pavarin, Emanuele Tonoli, Marco D'Agostino e Efrem Bonelli sono gli atleti confermati anche per il 2020, che continueranno a gareggiare sui campi di gara con il Bottecchia Factory.

From 2014 the BOTTECCHIA FACTORY TEAM, enters the "UCI TEAM" and participates in the main national and international competitions of primary importance. An all-Italian team that aims to emerge on the international scene thanks to a strong squad with great experience. Stefano Dal Grande, Marcello Pavarin, Emanuele Tonoli, Marco D'Agostino and Efrem Bonelli are the athletes confirmed also for 2020, who will continue to compete on the competition fields with the Bottecchia Factory.

PALMARES

Grande stagione per il Factory Team che ha affrontato un calendario di più di 30 gare nazionali.

Tanti podi e quasi la metà posizionati sul gradino più alto. Per il secondo anno consecutivo importante vittoria alla GF Kask Soave bike e primo e secondo posto alla 100 km dei Forti di Lavarone. Anche nei campionati italiani marathon il team con Stefano Dal Grande ha chiuso a ridosso della top 5. Vittoria anche della Monterosa Prestige con Dal Grande, seguito da Tonoli al terzo posto.

Great season for the Factory Team that has faced a calendar of more than 30 national races.

Many podiums and almost half of them on the highest step. For the second consecutive year, an important victory of GF Kask Soave bike and first and second place at the 100 km dei Forti of Lavarone. Even in the Italian marathon championships the team with Stefano Dal Grande closed just before the top 5. Victory also of the Monterosa Prestige with Dal Grande, followed by Tonoli at the third place.

0 PUNTI DI GIUNZIONE DEL TELAIO
FRAME JUNCTION POINTS

1 UNICO STAMPO MONOLITH
UNIQUE MONOLITH MOLD

930 gr PESO/WEIGHT

TOP PRO

100%



PRO

100%



AMATEUR

30%



LIGHTWEIGHT

100%



STIFFNESS

90%



COMFORT

80%



AQUILA ROSSA TEAM

RED⁺
LAB

ALLESTIMENTI / EQUIPMENTS

- 79N AQUILAROSSA Sram X01 eTap AXS 12s
- 79R AQUILAROSSA Sram XX1/X01 12s
- 79T AQUILAROSSA Sram X01/GX 12s
- 79F AQUILAROSSA Shimano XTR 12s
- 79Q AQUILAROSSA Shimano XT 12s

MONOLITH
TECHNOLOGY

79R AQUILA ROSSA TEAM

SRAM XX1/X01 12s

PESO / WEIGHT

9,280 Kg taglia M / size M

COLORE / COLOUR

cA1 Team



MTB HARD TAILS

AQUILA ROSSA

RED⁺
LAB

MCNOLITH
TECHNOLOGY

79N AQUILA ROSSA

SRAM X01 eTap AXS 12s

PESO / WEIGHT

10,160 Kg taglia M / size M

COLORE / COLOUR

c58 Red Lab



La migliore hard tail da competizione

Il top di gamma nel mountain ha un nuovo nome. AQUILA ROSSA è la MTB superleggera progettata per soddisfare le estreme esigenze dei bikers pro e agonisti di alto livello. Grazie alla tecnologia di produzione Monolith, il telaio in carbonio da 930 grammi prende struttura e forma interamente da un unico stampo in totale assenza di punti di giunzione, creando un vero e proprio monoscocca. Grazie alla omogeneità della distribuzione delle fibre di carbonio, il peso, la rigidità e la distribuzione delle vibrazioni su tutta la struttura ne beneficiano, portando ai massimi livelli le performance. Più veloce, stabile e reattiva con un comfort in termini di vibrazioni impareggiabile, grazie anche alle geometrie racing Boost e al carro estremamente compatto da 435 mm.

79F AQUILA ROSSA SHIMANO XTR 12s

PESO / WEIGHT

9,300 Kg taglia M / size M

COLORE / COLOUR

c10 Nero Opaco
c10 Matt Black

The best competition hard tail

The top of the mountain range has a new name. AQUILA ROSSA is the super light MTB designed to meet the extreme needs of high-level pro and competitive bikers. Thanks to the Monolith production technology, the 930-grams carbon frame takes structure and forms entirely from a single mold in total absence of junction points, creating a real monocoque. Thanks to the homogeneity of the distribution of the carbon fibers, the weight, the rigidity and the distribution of the vibrations on the whole structure benefit, bringing the performances to the maximum levels. Faster, stable and responsive with incomparable comfort in terms of vibrations, thanks also to the racing Boost geometries and the extremely compact 435 mm rear stay.

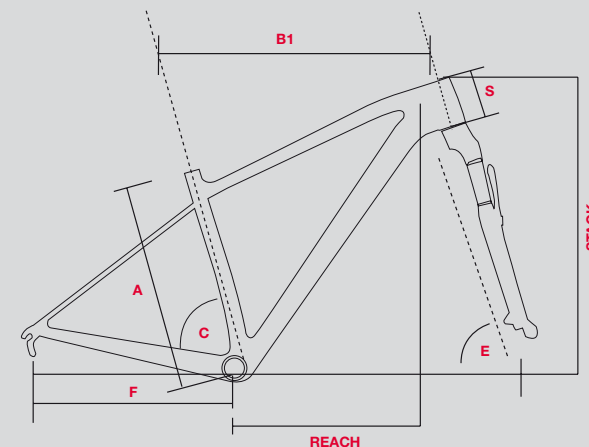

SIZE	A	B1	C	E	F	S	STACK	REACH
39	395	575	73.7°	69.5°	435	95	398	605
44	440	600	73.7°	69.5°	435	100	422	610
48	480	625	73.7°	69.5°	435	115	442	625
52	520	650	73.7°	69.5°	435	125	464	634

KT 79 AQUILA ROSSA

TELAIO / FRAME

Carbonio monoscocca MONOLITH HM 29 con asse passante da 12mm BOOST 148mm, predisposizione per Di2, cavi interni. Monocoque carbon MONOLITH HM 29 with thru axle 12mm, BOOST 148mm, suitable for Di2, internal cable routing.

MOVIMENTO / BB

Pressfit 92x41

STERZO / HEADTUBE

Integrato 1" 1/8 sopra 1" 1/2 sotto
Integrated 1" 1/8 up 1" 1/2 down

COLORI / COLOURS

cA1 Team, c58 Red Lab, c10 Nero Opaco / c10 Matt Black

PESO / WEIGHT

Taglia M grezzo 930g
Size M row 930g



ORTLES 297+

TOP PRO



PRO



AMATEUR



LIGHTWEIGHT



STIFFNESS



COMFORT



83R ORTLES 297+
SRAM XX1/X01 12s

PESO / WEIGHT
10,430 Kg taglia M / size M

COLORE / COLOUR
c39 Nero Grigio
c39 Black Grey

ALLESTIMENTI / EQUIPMENTS

- 83N ORTLES 297+ Sram X01 eTap AXS 12s
- 83R ORTLES 297+ Sram XX1/X01 12s
- 83T ORTLES 297+ Sram X01/GX 12s
- 83U ORTLES 297+ Sram NX1 12s
- 83V ORTLES 297+ Sram SX 12s
- 83Q ORTLES 297+ Shimano XT 12s
- 83A ORTLES 297+ Shimano XT/DEORE 20s



Prestazioni da podio, carattere da fuoriclasse

Quando cerchi le migliori prestazioni nella MTB non puoi accettare compromessi. Per questo in questo telaio abbiamo trovato la combinazione ottimale tra rigidità e assorbimento delle sollecitazioni della ruota posteriore. Il carro estremamente compatto e reattivo con scarico parziale delle vibrazioni posteriori sul top tube e la conformazione Boost con interasse posteriore da 148mm, conferiscono caratteristiche ready for race a questo telaio. La possibilità di usare ruote da 29" fino a 2.35 di sezione e l'avantreno particolarmente stabile e maneggevole, rendono ORTLES 297+ adatta a tutti i tuoi trail. Grande attenzione merita l'area del movimento centrale, disegnata per il carro posteriore Boost corto e reattivo, e strutturalmente progettato per supportare perfettamente lo stress a cui è sottoposto.

83Q ORTLES 297+

SHIMANO XT 12s

PESO / WEIGHT

10,680 Kg taglia M / size M

COLORE / COLOUR

c58 Red Lab

Top performances, outstanding character

No compromises can be accepted when looking for the best MTB performance. For this reason we have found in this frame the optimal combination of rigidity and stress absorption of the rear wheel. The extremely compact and responsive rear stay with partial exhaust of the rear vibrations on the top tube and the Boost conformation with a 148mm rear center to center distance, make this frame ready to race.

The possibility of using 29" wheels up to 2.35 section and the particularly stable and manageable front make ORTLES 297+ suitable for all your routes.

The BB set area deserves great attention, designed for the short and responsive Boost rear stay, and structurally designed to perfectly support the stress to which it is subjected.

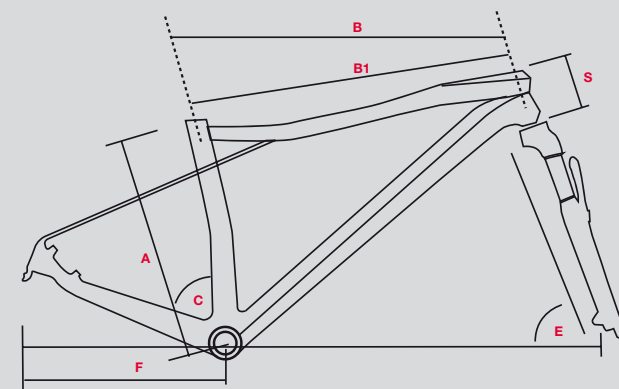

SIZE	A	B	B1	C	E	F	S	STACK	REACH
43	430	570	585	73°	71°	445	100	647	399
48	480	580	605	73°	71°	445	105	651	418
53	530	600	630	73°	71°	445	110	656	441

KT 83 ORTLES 297+

TELAIO / FRAME

Carbonio monoscocca UD HM 29 con asse passante da 12mm, BOOST 148mm, predisposizione per Di2.
Monocoque carbon UD HM 29 with thru axle 12mm, BOOST 148mm, suitable for Di2.

MOVIMENTO / BB

Pressfit 92x41 mm

STERZO / HEADTUBE

Integrato 1" 1/8 sopra 1" 1/2 sotto
Integrated 1" 1/8 up 1" 1/2 down

COLORI / COLOURS

c58 Red Lab, c39 Nero Grigio / c39 Black Grey

PESO / WEIGHT

Taglia M grezzo 1140g
Size M raw 1140g





STELVIO 297+

ALLESTIMENTI / EQUIPMENTS

85C	STELVIO 297 Shimano XT 22s
85Q	STELVIO 297 Shimano XT 12s
85A	STELVIO 297 Shimano XT/DEORE 20s
85W	STELVIO 297 Sram GX/SX 12s
85V	STELVIO 297 Sram SX 12s
85S	STELVIO 297 Sram NX1 11s

85V STELVIO 297+

SRAM SX1 12s

PESO / WEIGHT

13,800 Kg taglia M / SIZE M

COLORE / COLOUR

c83 Antracite Giallo Opaco

c83 Matt Anthracite Yellow

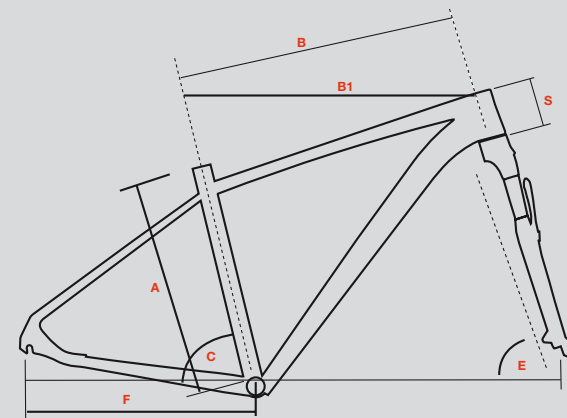

SIZE	A	B	B1	C	E	F	S
40	400	577.7	585	74°	71°	450	105
44	440	585	600	74°	71°	450	110
48	480	596	615	74°	71°	450	130
52	520	608	630	74°	71°	450	140

KT 85 STELVIO 297+

TELAIO / FRAME

Alluminio 6061 doppio spessore 29, forcellino 3d con post mount integrato.

Aluminium 6061 double butted 29, 3d dropout with integrated post mount.

MOVIMENTO / BB

Pressfit 92mm

STERZO / HEADTUBE

Integrato 1" 1/8 sopra 1" 1/2 sotto

Integrated 1" 1/8 up 1" 1/2 down

COLORI / COLOURS

c83 Antracite Giallo Opaco

c83 Matt Anthracite Yellow

PESO / WEIGHT

Taglia M grezzo 1700g

Size M raw 1700g



GAVIA 29"

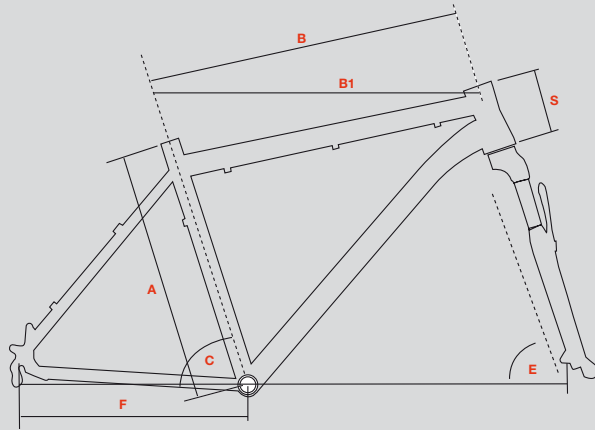

SIZE	A	B	B1	C	E	F	S
40	400	549	580	74°	72°	450	110
43	430	566	590	73°	71,5°	450	110
48	480	584	610	73°	71,5°	450	125
53	530	605	630	73°	71,5°	450	145

KT 87 GAVIA 29"

TELAIO / FRAME

Alluminio 6061 doppio spessore 29" idroformato
Aluminium 6061 double butted 29" hydroformed

MOVIMENTO / BB

BSA 68mm

STERZO / HEADTUBE

Integrato 1" 1/8
Integrated 1"1/8

COLORI / COLOURS

c65 Nero Verde Fluo Opaco, c91 Antracite Rosso
c65 Matt Black Green Fluo, c91 Anthracite Red

PESO / WEIGHT

Taglia M grezzo 1850g
Size M raw 1850g

87A GAVIA 29"

SHIMANO XT/DEORE 20s

PESO / WEIGHT

14,600 Kg taglia M / size M

COLORE / COLOUR

c91 Antracite Rosso
c91 Anthracite Red



87V GAVIA 29"

SRAM SX 12s

PESO / WEIGHT

14,100 Kg taglia M / SIZE M

COLORE / COLOUR

c65 Nero Verde Fluo Opaco
c65 Matt Black Green Fluo

TONALE 29"

89E TONALE 29"

SHIMANO ALIVIO 27s

PESO / WEIGHT

14,800 Kg taglia M / size M

COLORE / COLOUR

c65 Nero Verde Fluo Opaco

c65 Matt Black Green Fluo

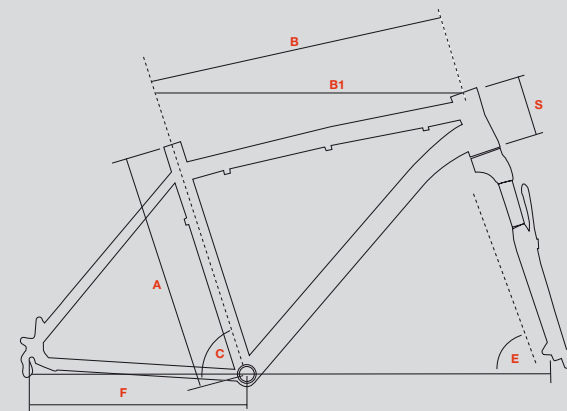

SIZE	A	B	B1	C	E	F	S
40	400	576	590	74°	72°	450	110
44	440	581	602	74°	72°	450	110
48	480	598	622	74°	72°	450	120
52	520	610	635	74°	72°	450	130

KIT 89 TONALE 29"

TELAIO / FRAME

Alluminio 6061 doppio spessore 29" idroformato
Aluminium 6061 double butted 29" hydroformed

MOVIMENTO / BB

BSA 68mm

STERZO / HEADTUBE

Integrato 1" 1/8
Integrated 1"1/8

COLORI / COLOURS

c65 Nero Verde Fluo Opaco
c65 Matt Black Green Fluo

PESO / WEIGHT

Taglia M grezzo 1850g
Size M raw 1850g

MTB FULL SUSP.

GARDENA 29" BOOST

ALLESTIMENTI / EQUIPMENTS

91F	GARDENA 29 BOOST Shimano XTR 12s
91Q	GARDENA 29 BOOST Shimano XT 12s
91R	GARDENA 29 BOOST Sram XX1/X01 12S
91T	GARDENA 29 BOOST Sram X01/GX 12s
91W	GARDENA 29 BOOST Sram GX/SX 12s

91R GARDENA 29" BOOST
SRAM XX1/X01 12s

PESO / WEIGHT

11,650 Kg taglia M / size M

COLORE / COLOUR

c81 Nero Rosso
c81 Black Red



95T FEDAIA 27,5"

SRAM X01/GX 12s

PESO / WEIGHT

13,510 Kg taglia M / size M

COLORE / COLOUR

c09 Carbonio Opaco

c09 Matt Carbon



FEDAIA 27,5"

ALLESTIMENTI / EQUIPMENTS

95T FEDAIA 27,5 Sram X01/GX 12s

95W FEDAIA 27,5 Sram GX/SX 12s

TOP PRO



PRO



AMATEUR



LIGHTWEIGHT



STIFFNESS



COMFORT



Conquista la salita e goditi la discesa con la nostra full carbon da enduro

Fedaia è la biammortizzata in carbonio con escursione da 160 mm adatta a sfidare i track più impegnativi grazie al peso ridotto e alle doppie sospensioni. La guida maneggevole e affidabile permette di godere della montagna a 360 gradi. Agile e veloce offre il massimo divertimento nel suo habitat naturale: il fuori strada.

Conquer the hill and enjoy the downhill with our full carbon enduro

Fedaia is the full carbon suspension with 160 mm travel, suitable for challenging the most demanding tracks thanks to its low weight and double suspensions. The handy and reliable guide allows you to enjoy the mountain 360 degrees. Agile and fast, it offers great fun in its natural habitat: off-road.

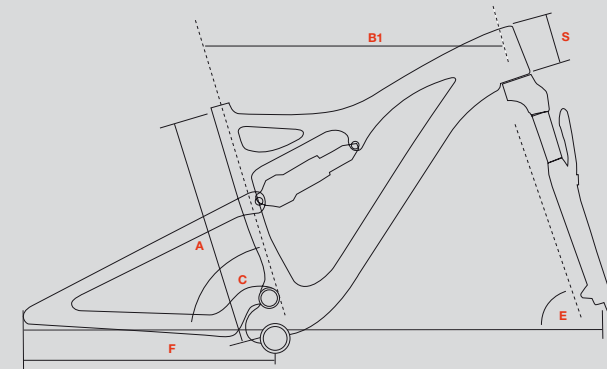

SIZE	A	B1	C	E	F	S
44	440	600	74°	68°	440	110
48	480	620	74°	68,5°	440	120

KT 95 FEDAIA 27,5"

TELAIO / FRAME

Full suspension Carbonio UD all mountain escursione 160 mm
Full suspension Carbon UD all mountain travel 160 mm

MOVIMENTO / BB

Pressfit 92 mm

STERZO / HEADTUBE

Integrato 1" 1/8 sopra 1"1/2 sotto
Integrated 1"1/8 up 1"1/2 down

COLORI / COLOURS

c09 Carbonio Opaco
c09 Matt Carbon

PESO / WEIGHT

Taglia M grezzo 2680g
Size M raw 2680g

MTB FAT BIKE

CERVINO 26"

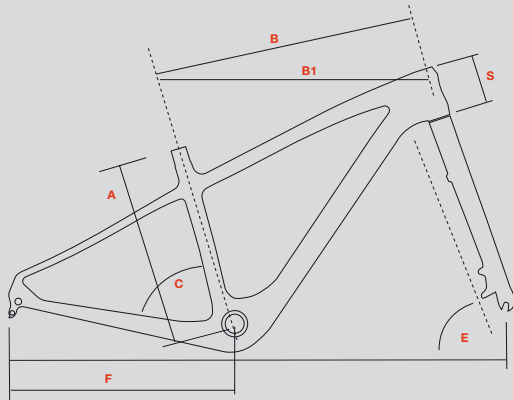

SIZE	A	B	B1	C	E	F	S
44	440	570	593	73,5	70,5°	455	140
48	480	595	620	73,5	70,5°	455	160

KT 145 CERVINO 26"

TELAIO / FRAME

Alluminio 6061 doppio spessore 26" idroformato
Aluminium 6061 hydroformed double butted

MOVIMENTO / BB

BSA 68mm

STERZO / HEADTUBE

Integrato 1" 1/8 sopra e 1" 1/2 sotto
integrated 1" 1/8 up and 1" 1/2 down

COLORI / COLOURS

c29 Nero Rosso Fluo Opaco
c29 Matt Black Red Fluo

PESO / WEIGHT

Taglia M grezzo 2300g
Size M row 2300g

145 CERVINO FAT 26"
SHIMANO XT/DEORE 20s

PESO / WEIGHT

14,900 Kg taglia M / size M

COLORE / COLOUR

c29 Nero Rosso Fluo Opaco
c29 Black Red Fluo Matt



SENALES 26"

140 SENALES FAT 26"
SHIMANO ALIVIO 18s

PESO / WEIGHT
 15,500 Kg taglia M / size M

COLORE / COLOUR
 c82 Arancio Opaco
 c82 Matt Orange

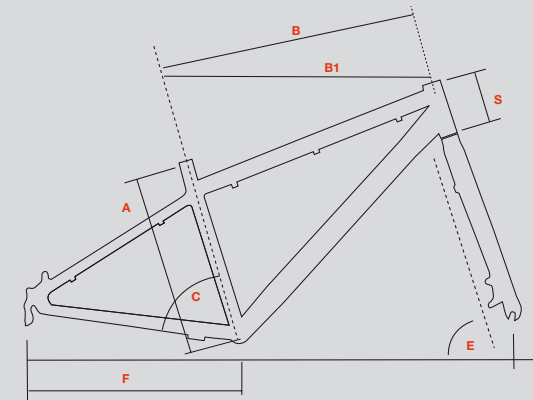

SIZE	A	B	B1	C	E	F	S
44	440	570	590	73°	69°	455	130
48	480	580	605	73°	69°	455	130

KT 140 SENALES 26"

TELAIO / FRAME

Alluminio 6061 FAT BIKE 26"
 Aluminium 6061 FAT BIKE 26"

MOVIMENTO / BB

BSA 68mm

STERZO / HEADTUBE

Semi Integrato 1" 1/8
 Semi Integrated 1"1/8

COLORI / COLOURS

c82 Arancio Opaco, c83 Antracite Giallo
 c82 Matt Orange, c83 Anthracite Yellow

PESO / WEIGHT

Taglia M grezzo 2300g
 Size M raw 2300g

140 SENALES FAT 26"
SHIMANO ALIVIO 18s

PESO / WEIGHT
 15,500 Kg taglia M / size M

COLORE / COLOUR
 c83 Antracite Giallo
 c83 Anthracite Yellow

SPORTSWEAR



COMPLETO ESTIVO / SUMMER SUIT

ABR2 Maglia manica corta / T-shirt
 ABR3 Pantaloncino estivo / Bib shorts
 Colore / Colour: Nero Rosso / Black Red
 Taglia / Size: S-M-L-XL-XXL



COMPLETO ESTIVO PRO / PRO SUMMER SUIT

ATPRO Maglia manica corta pro / Pro T-shirt
 ABPRO Pantaloncino estivo pro / Pro bib shorts
 Colore / Colour: Rosso / Red
 Taglia / Size: S-M-L-XL-XXL



BB9 GUANTO INVERNALE / WINTER GLOVES

Colore / Colour: Bianco Nero / White Black
 Taglia / Size: M-L-XL



COMPLETO INVERNALE / WINTER SUIT

ABR5 Giubbotto invernale Wintex/ Wintex winter jacket
 ABR4 Calzamaglia invernale/ Winter tights
 Colore / Colour: Nero Rosso / Black Red
 Taglia / Size: S-M-L-XL-XXL



COMPLETO GRAVEL / GRAVEL SUIT

ATGRA Maglia Gravel manica corta / Gravel T-shirt
 ABGRA Pantaloncino Gravel / Gravel Shorts
 Colore / Colour: Grigio Nero / Grey Black
 Taglia / Size: S-M-L-XL-XXL



BB6 GUANTO ESTIVO / SUMMER GLOVES

Colore / Colour: Nero Rosso / Red Black
 Taglia / Size: M-L-XL

CASUAL



LFS6 GIUBBINO SOFTSHELL / SOFTSHELL JACKET
Colore / Colour: Nero Rosso / Black Red
Taglia / Size: S-M-L-XL



LFS15 CAPPELLINO / BASEBALL CAP
Colore / Colour: Nero / Black



LFS20 T-SHIRT
Colore / Colour: Nero / Black
Taglia / Size: S-M-L-XL

MERCHANDISING



PETTORINA DA LAVORO / APRON
Colore / Colour: Nero / Black
Taglia / Size: Unica / One Size



GAZEBO
Colore / Colour: Nero Rosso / Black Red
Dimensioni / Dimensions: 3x3m



STRISCIONE TNT / TNT BANNER
Colore / Colour: Nero / Black
Dimensioni / Dimensions: 80x250 cm



BANDIERA / FLAG
Colore / Colour: Nero Rosso / Black Red
Dimensioni / Dimensions: FLAG-S 2m, FLAG-L 5m

EMME 4 SUPERLIGHT

ALLESTIMENTI / EQUIPMENTS		GRUPPO GEAR	CAMBIO REAR DERAILLEUR	COMANDI SHIFTER	GUARNITURA CHAINWHEEL	RUOTE WHEELS	CASSETTA CASSETTE	FRENI BRAKES	COPERTURE TIRES	PIEGA HANDLEBAR	PIANTONE STEM	REGGISILLA SEAT POST	SELLA SADDLE
73LD	EMME 4 SUPERLIGHT Campagnolo Super Record 24s DISK	Campagnolo Super Record 24s DISK	Campagnolo Super Record 24s	Campagnolo Super Record 24s DISK	Campagnolo Super Record 52/36 24s	Campagnolo Bora One DISK 50mm clincher	Campagnolo Super Record 11/32 12s	Campagnolo Super Record DISK 160/160	Vittoria clincher SPEED TLR G+ 700x25	Deda Superzero Carbon	Deda Superzero	Deda RS Zero 27.2	SAN MARCO Aspid2 CARBON
73GD	EMME 4 SUPERLIGHT Campagnolo Chorus 24s DISK	Campagnolo Chorus 24s DISK	Campagnolo Chorus 24s	Campagnolo Chorus 24s DISK	Campagnolo Chorus 50/34 24s	Fulcrum Racing 400 DISK	Campagnolo Chorus 11/32 12s	Campagnolo Chorus DISK 160/160	Vittoria Zaffiro fold 700x25	Deda RHM Zero	Deda Zero	Deda RS Zero 27.2	SAN MARCO Era/Monza str
73A	EMME 4 SUPERLIGHT Sram Red eTap AXS 24s DISK	Sram Red eTap AXS 24s DISK	Sram Red eTap AXS 24s	Sram Red eTap AXS 24s DISK	Sram Red eTap AXS 48/35 24s	Fulcrum Wind 400 Carbon DISK	Sram Red 10/28 12s	Sram Red eTap AXS DISK 160/160	Vittoria clincher SPEED TLR G+ 700x25	Deda Superzero Carbon	Deda Superzero	Deda Superzero Carbon 27.2	SAN MARCO Aspid2 RED LAB
73F	EMME 4 SUPERLIGHT Sram Force eTap AXS 24s DISK	Sram Force eTap AXS 24s DISK	Sram Force eTap AXS 24s	Sram Force eTap AXS 24s DISK	Sram Force eTap AXS 48/35 24s	Miche Revox Carbon	Sram Force 10/28 12s	Sram Force eTap AXS DISK 160/160	Vittoria Rubino PRO fold 700x25	Deda RHM Zero	Deda Zero	Deda RS Zero 27.2	SAN MARCO Era/Monza str
73TD	EMME 4 SUPERLIGHT Shimano Dura Ace Di2 22s DISK	Shimano Dura Ace Di2 22s DISK	Shimano Dura Ace Di2 22s	Shimano Dura Ace Di2 22s DISK	Shimano Dura Ace 52/36 22s	Fulcrum Wind 400 Carbon DISK	Shimano Dura Ace 11/28-11/30 11s	Shimano 9170 Di2 DISK 140/160	Vittoria clincher SPEED TLR G+ 700x25	Deda Superzero Carbon	Deda Superzero	Deda Superzero Carbon 27.2	SAN MARCO Aspid2 RED LAB
73X	EMME 4 SUPERLIGHT Shimano Dura Ace 22s DISK	Shimano Dura Ace 22s DISK	Shimano Dura Ace 22s	Shimano Dura Ace 22s DISK	Shimano Dura Ace 52/36 22s	Fulcrum Wind 400 Carbon DISK	Shimano Dura Ace 11/28-11/30 11s	Shimano 9170 DISK 140/160	Vittoria clincher SPEED TLR G+ 700x25	Deda Superzero Carbon	Deda Superzero	Deda Superzero Carbon 27.2	SAN MARCO Aspid2 RED LAB
73S	EMME 4 SUPERLIGHT Shimano Dura Ace 22s	Shimano Dura Ace 22s	Shimano Dura Ace 22s	Shimano Dura Ace 22s	Shimano Dura Ace 52/36 22s	Miche Revox Carbon	Shimano Dura Ace 11/28-11/30 11s	Shimano 9100	Vittoria clincher SPEED TLR G+ 700x25	Deda Superzero Carbon	Deda Superzero	Deda Superzero Carbon 27.2	SAN MARCO Aspid2 RED LAB
73RD	EMME 4 SUPERLIGHT Shimano Ultegra Di2 22s DISK	Shimano Ultegra Di2 22s DISK	Shimano Ultegra Di2 22s	Shimano Ultegra Di2 22s DISK	Shimano Ultegra 52/36 22s	Miche Revox Carbon	Shimano Ultegra 11/30-11/32 11s	Shimano 8070 Di2 DISK 140/160	Vittoria Rubino PRO fold 700x25	Deda RHM Zero	Deda Zero	Deda RS Zero 27.2	SAN MARCO Era/Monza str
73Y	EMME 4 SUPERLIGHT Shimano Ultegra 22s DISK	Shimano Ultegra 22s DISK	Shimano Ultegra 22s	Shimano Ultegra 22s DISK	Shimano Ultegra 52/36 22s	Fulcrum Racing 900 DISK Miche Race DISK	Shimano Ultegra 11/30-11/32 11s	Shimano 8070 DISK 140/160	Vittoria Zaffiro fold 700x25	Deda RHM Zero	Deda Zero	Deda RS Zero 27.2	SAN MARCO Era/Monza str
73Q	EMME 4 SUPERLIGHT Shimano Ultegra 22s	Shimano Ultegra 22s	Shimano Ultegra 22s	Shimano Ultegra 22s	Shimano Ultegra 52/36 22s	Fulcrum Racing 4/400	Shimano Ultegra 11/30-11/32 11s	Shimano 8000	Vittoria Rubino fold 700x25	Deda RHM Zero	Deda Zero	Deda RS Zero 27.2	SAN MARCO Era/Monza str

AEROSPACE

ALLESTIMENTI / EQUIPMENTS		GRUPPO GEAR	CAMBIO REAR DERAILLEUR	COMANDI SHIFTER	GUARNITURA CHAINWHEEL	RUOTE WHEELS	CASSETTA CASSETTE	FRENI BRAKES	COPERTURE TIRES	PIEGA HANDLEBAR	PIANTONE STEM	REGGISILLA SEAT POST	SELLA SADDLE
65LD	AEROSPACE Campagnolo Super Record 24s DISK	Campagnolo Super Record 24s DISK	Campagnolo Super Record 24s	Campagnolo Super Record 24s DISK	Campagnolo Super Record 52/36 24s	Campagnolo Bora One DISK 50mm clincher	Campagnolo Super Record 11/32 12s	Campagnolo Super Record DISK 160/160	Vittoria clincher SPEED TLR G+ 700x25	Deda Superzero Carbon	AEROSPACE Integrated Carbon	AEROSPACE Carbon	SAN MARCO Aspid2 RED LAB
65GD	AEROSPACE Campagnolo Chorus 24s DISK	Campagnolo Chorus 24s DISK	Campagnolo Chorus 24s	Campagnolo Chorus 24s DISK	Campagnolo Chorus 50/34 24s	Fulcrum Racing 400 DISK	Campagnolo Chorus 11/32 12s	Campagnolo Chorus DISK 160/160	Vittoria Zaffiro fold 700x25	Deda RHM Zero	AEROSPACE Integrated Carbon	AEROSPACE Carbon	SAN MARCO Era/Monza str
65A	AEROSPACE Sram Red eTap AXS 24s DISK	Sram Red eTap AXS 24s DISK	Sram Red eTap AXS 24s	Sram Red eTap AXS 24s DISK	Sram Red eTap AXS 48/35 24s	Fulcrum Wind 400 Carbon DISK	Sram Red 10/28 12s	Sram Red eTap AXS DISK 160/160	Vittoria clincher SPEED TLR G+ 700x25	Deda Superzero Carbon	AEROSPACE Integrated Carbon	AEROSPACE Carbon	SAN MARCO Aspid2 RED LAB
65F	AEROSPACE Sram Force eTap AXS 24s DISK	Sram Force eTap AXS 24s DISK	Sram Force eTap AXS 24s	Sram Force eTap AXS 24s DISK	Sram Force eTap AXS 48/35 24s	Miche Revox Carbon	Sram Force 10/28 12s	Sram Force eTap AXS DISK 160/160	Vittoria Rubino PRO fold 700x25	Deda RHM Zero	AEROSPACE Integrated Carbon	AEROSPACE Carbon	SAN MARCO Era/Monza str
65TD	AEROSPACE Shimano Dura Ace Di2 22s DISK	Shimano Dura Ace Di2 22s DISK	Shimano Dura Ace Di2 22s	Shimano Dura Ace Di2 22s DISK	Shimano Dura Ace 52/36 22s	Fulcrum Wind 400 Carbon DISK	Shimano Dura Ace 11/28-11/30 11s	Shimano 9170 Di2 DISK 140/160	Vittoria clincher SPEED TLR G+ 700x25	Deda Superzero Carbon	AEROSPACE Integrated Carbon	AEROSPACE Carbon	SAN MARCO Aspid2 RED LAB
65X	AEROSPACE Shimano Dura Ace 22s DISK	Shimano Dura Ace 22s DISK	Shimano Dura Ace 22s	Shimano Dura Ace 22s DISK	Shimano Dura Ace 52/36 22s	Fulcrum Wind 400 Carbon DISK	Shimano Dura Ace 11/28-11/30 11s	Shimano 9170 DISK 140/160	Vittoria clincher SPEED TLR G+ 700x25	Deda Superzero Carbon	AEROSPACE Integrated Carbon	AEROSPACE Carbon	SAN MARCO Aspid2 RED LAB
65RD	AEROSPACE Shimano Ultegra Di2 22s DISK	Shimano Ultegra Di2 22s DISK	Shimano Ultegra Di2 22s	Shimano Ultegra Di2 22s DISK	Shimano Ultegra 52/36 22s	Miche Revox Carbon	Shimano Ultegra 11/30-11/32 11s	Shimano 8070 Di2 DISK 140/160	Vittoria Rubino PRO fold 700x25	Deda RHM Zero	AEROSPACE Integrated Carbon	AEROSPACE Carbon	SAN MARCO Era/Monza str
65Y	AEROSPACE Shimano Ultegra 22s DISK	Shimano Ultegra 22s DISK	Shimano Ultegra 22s	Shimano Ultegra 22s DISK	Shimano Ultegra 52/36 22s	Fulcrum Racing 900 DISK Miche Race DISK	Shimano Ultegra 11/30-11/32 11s	Shimano 8070 DISK 140/160	Vittoria Zaffiro fold 700x25	Deda RHM Zero	AEROSPACE Integrated Carbon	AEROSPACE Carbon	SAN MARCO Era/Monza str
65D	AEROSPACE Shimano 105 22s DISK	Shimano 105 22s DISK	Shimano 105 22s	Shimano 105 22s DISK	Shimano 105 50/34 22s	Fulcrum Racing 900 DISK Miche Race DISK	Shimano 105 11/34 11s	Shimano 7070 DISK 140/160	Vittoria Zaffiro fold 700x25	Deda RHM Zero	AEROSPACE Integrated Carbon	AEROSPACE Carbon	SAN MARCO Era/Monza str

T2 DOPPIA CORSA

ALLESTIMENTI / EQUIPMENTS		GRUPPO GEAR	CAMBIO REAR DERAILLEUR	COMANDI SHIFTER	GUARNITURA CHAINWHEEL	RUOTE WHEELS	CASSETTA CASSETTE	FRENI BRAKES	COPERTURE TIRES	PIEGA HANDLEBAR	PIANTONE STEM	REGGISSELLA SEAT POST	SELLA SADDLE
67LD	T2 DOPPIA CORSA Campagnolo Super Record 24s DISK	Campagnolo Super Record 24s DISK	Campagnolo Super Record 24s	Campagnolo Super Record 24s DISK	Campagnolo Super Record 52/36 24s	Campagnolo Bora One DISK 50mm clincher	Campagnolo Super Record 11/32 12s	Campagnolo Super Record DISK 160/160	Vittoria clincher SPEED TLR G+ 700x25	Deda Superzero Carbon	Deda Superzero	T2 DOPPIA CORSA Carbon Aero	SAN MARCO Aspide2 RED LAB
67GD	T2 DOPPIA CORSA Campagnolo Chorus 24s DISK	Campagnolo Chorus 24s DISK	Campagnolo Chorus 24s	Campagnolo Chorus 24s DISK	Campagnolo Chorus 50/34 24s	Fulcrum Racing 400 DISK	Campagnolo Chorus 11/32 12s	Campagnolo Chorus DISK 160/160	Vittoria Zaffiro fold 700x25	Deda RHM Zero	Deda Zero	T2 DOPPIA CORSA Carbon Aero	SAN MARCO Era/Monza str
67A	T2 DOPPIA CORSA Sram Red eTap AXS 24s DISK	Sram Red eTap AXS 24s DISK	Sram Red eTap AXS 24s	Sram Red eTap AXS 24s DISK	Sram Red eTap AXS 48/35 24s	Fulcrum Wind 400 Carbon DISK	Sram Red 10/28 12s	Sram Red eTap AXS DISK 160/160	Vittoria clincher SPEED TLR G+ 700x25	Deda Superzero Carbon	Deda Superzero	T2 DOPPIA CORSA Carbon Aero	SAN MARCO Aspide2 RED LAB
67F	T2 DOPPIA CORSA Sram Force eTap AXS 24s DISK	Sram Force eTap AXS 24s DISK	Sram Force eTap AXS 24s	Sram Force eTap AXS 24s DISK	Sram Force eTap AXS 48/35 24s	Miche Revox Carbon	Sram Force 10/28 12s	Sram Force eTap AXS DISK 160/160	Vittoria Rubino PRO fold 700x25	Deda RHM Zero	Deda Zero	T2 DOPPIA CORSA Carbon Aero	SAN MARCO Era/Monza str
67TD	T2 DOPPIA CORSA Shimano Dura Ace Di2 22s DISK	Shimano Dura Ace Di2 22s DISK	Shimano Dura Ace Di2 22s	Shimano Dura Ace Di2 22s DISK	Shimano Dura Ace 52/36 22s	Fulcrum Wind 400 Carbon DISK	Shimano Dura Ace 11/28-11/30 11s	Shimano 9170 Di2 DISK 140/160	Vittoria clincher SPEED TLR G+ 700x25	Deda Superzero Carbon	Deda Superzero	T2 DOPPIA CORSA Carbon Aero	SAN MARCO Aspide2 RED LAB
67X	T2 DOPPIA CORSA Shimano Dura Ace 22s DISK	Shimano Dura Ace 22s DISK	Shimano Dura Ace 22s	Shimano Dura Ace 22s DISK	Shimano Dura Ace 52/36 22s	Fulcrum Wind 400 Carbon DISK	Shimano Dura Ace 11/28-11/30 11s	Shimano 9170 DISK 140/160	Vittoria clincher SPEED TLR G+ 700x25	Deda Superzero Carbon	Deda Superzero	T2 DOPPIA CORSA Carbon Aero	SAN MARCO Aspide2 RED LAB
67S	T2 DOPPIA CORSA Shimano Dura Ace 22s	Shimano Dura Ace 22s	Shimano Dura Ace 22s	Shimano Dura Ace 22s	Shimano Dura Ace 52/36 22s	Fulcrum Racing 4 Carbon clincher h40	Shimano Dura Ace 11/28-11/30 11s	Shimano 9100	Vittoria clincher SPEED TLR G+ 700x25	Deda Superzero Carbon	Deda Superzero	T2 DOPPIA CORSA Carbon Aero	SAN MARCO Aspide2 RED LAB
67RD	T2 DOPPIA CORSA Shimano Ultegra Di2 22s DISK	Shimano Ultegra Di2 22s DISK	Shimano Ultegra Di2 22s	Shimano Ultegra Di2 22s DISK	Shimano Ultegra 52/36 22s	Fulcrum Racing DB 900 DISK	Shimano Ultegra 11/30-11/32 11s	Shimano 8070 Di2 DISK 140/160	Vittoria Zaffiro fold 700x25	Deda RHM Zero	Deda Zero	T2 DOPPIA CORSA Carbon Aero	SAN MARCO Aspide2 RED LAB
67Y	T2 DOPPIA CORSA Shimano Ultegra 22s DISK	Shimano Ultegra 22s DISK	Shimano Ultegra 22s	Shimano Ultegra 22s DISK	Shimano Ultegra 52/36 22s	Fulcrum Racing DB 900 DISK	Shimano Ultegra 11/30-11/32 11s	Shimano 8070 DISK 140/160	Vittoria Zaffiro fold 700x25	Deda RHM Zero	Deda Zero	T2 DOPPIA CORSA Carbon Aero	SAN MARCO Aspide2 RED LAB
67Q	T2 DOPPIA CORSA Shimano Ultegra 22s	Shimano Ultegra 22s	Shimano Ultegra 22s	Shimano Ultegra 22s	Shimano Ultegra 52/36 22s	Fulcrum Racing Sport	Shimano Ultegra 11/30-11/32 11s	Shimano 8000	Vittoria Zaffiro fold 700x25	Deda RHM Zero	Deda Zero	T2 DOPPIA CORSA Carbon Aero	SAN MARCO Aspide2 RED LAB

T1 ENDURANCE

ALLESTIMENTI / EQUIPMENTS		GRUPPO GEAR	CAMBIO REAR DERAILLEUR	COMANDI SHIFTER	GUARNITURA CHAINWHEEL	RUOTE WHEELS	CASSETTA CASSETTE	FRENI BRAKES	COPERTURE TIRES	PIEGA HANDLEBAR	PIANTONE STEM	REGGISSELLA SEAT POST	SELLA SADDLE
66L	T1 ENDURANCE Campagnolo Super Record 24s	Campagnolo Super Record 24s	Campagnolo Super Record 24s	Campagnolo Super Record 24s	Campagnolo Super Record 52/36 24s	Fulcrum Racing 4 Carbon clincher h40	Campagnolo Super Record 11/32 12s	Campagnolo Super Record	Vittoria clincher SPEED TLR G+ 700x25	Superzero Carbon	Deda Superzero	T1 ENDURANCE Carbon Aero	SAN MARCO Aspide CARBON
66V	T1 ENDURANCE Campagnolo Potenza 22s	Campagnolo Potenza 22s	Campagnolo Potenza 22s	Campagnolo Potenza 22s	Campagnolo Potenza Alu 52/36 22s	Miche RX7	Campagnolo Potenza 11/29 11s	Campagnolo Potenza	Vittoria Zaffiro fold 700x25	Deda RHM Zero	Raxe Super Light	T1 ENDURANCE Carbon Aero	SAN MARCO Monza str
66C	T1 ENDURANCE Campagnolo Centaur 22s	Campagnolo Centaur 22s	Campagnolo Centaur 22s	Campagnolo Centaur 22s	Campagnolo Centaur Alu 52/36 22s	Miche RX7	Campagnolo Centaur 11/32 11s	Campagnolo Centaur	Vittoria Zaffiro fold 700x25	Deda RHM Zero	Raxe Alu Light	T1 ENDURANCE Carbon Aero	SAN MARCO Monza str
66T	T1 ENDURANCE Shimano Dura Ace Di2 22s	Shimano Dura Ace Di2 22s	Shimano Dura Ace Di2 22s	Shimano Dura Ace Di2 22s	Shimano Dura Ace 52/36 22s	Fulcrum Racing 4 Carbon clincher h40	Shimano Dura Ace 11/28-11/30 11s	Shimano 9150 Di2	Vittoria clincher SPEED TLR G+ 700x25	Deda RHM Zero 2	Deda Zero 2	T1 ENDURANCE Carbon Aero	SAN MARCO Era/Monza str
66S	T1 ENDURANCE Shimano Dura Ace 22s	Shimano Dura Ace 22s	Shimano Dura Ace 22s	Shimano Dura Ace 22s	Shimano Dura Ace 52/36 22s	Fulcrum Racing 4/400	Shimano Dura Ace 11/28-11/30 11s	Shimano 9100	Vittoria Rubino PRO fold 700x25	Deda RHM Zero 2	Deda Zero 2	T1 ENDURANCE Carbon Aero	SAN MARCO Era/Monza str
66R	T1 ENDURANCE Shimano Ultegra Di2 22s	Shimano Ultegra Di2 22s	Shimano Ultegra Di2 22s	Shimano Ultegra Di2 22s	Shimano Ultegra 52/36 22s	Fulcrum Racing 4/400	Shimano Ultegra 11/30-11/32 11s	Shimano 8050 Di2	Vittoria Zaffiro fold 700x25	Deda RHM Zero	Raxe Super Light	T1 ENDURANCE Carbon Aero	SAN MARCO Monza str
66Q	T1 ENDURANCE Shimano Ultegra 22s	Shimano Ultegra 22s	Shimano Ultegra 22s	Shimano Ultegra 22s	Shimano Ultegra 52/36 22s	Fulcrum Racing Sport	Shimano Ultegra 11/30-11/32 11s	Shimano 8000	Vittoria Zaffiro fold 700x25	Deda RHM Zero	Raxe Super Light	T1 ENDURANCE Carbon Aero	SAN MARCO Monza str
66P	T1 ENDURANCE Shimano 105 / Ultegra Mix 22s	Shimano 105 / Ultegra Mix 22s	Shimano Ultegra 22s	FSA Omega Megaexo Alu 34/50 22s	Shimano 105 50/34 22s	Miche RX7	Shimano 105 11/28 11s	Shimano 7000	Vittoria Zaffiro fold 700x25	Deda RHM Zero	Raxe Alu Light	T1 ENDURANCE Carbon Aero	SAN MARCO Monza str
66O	T1 ENDURANCE Shimano 105 22s	Shimano 105 22s	Shimano 105 22s	Shimano 105 22s	Shimano 105 50/34 22s	Miche RX7	Shimano 105 11/28 11s	Shimano 7000	Vittoria Zaffiro fold 700x25	Deda RHM Zero	Raxe Alu Light	T1 ENDURANCE Carbon Aero	SAN MARCO Monza str

8AVIO REVOLUTION

ALLESTIMENTI / EQUIPMENTS		GRUPPO GEAR	CAMBIO REAR DERAILLEUR	COMANDI SHIFTER	GUARNITURA CHAINWHEEL	RUOTE WHEELS	CASSETTA CASSETTE	FRENI BRAKES	COPERTURE TIRES	PIEGA HANDLEBAR	PIANTONE STEM	REGGISSELLA SEAT POST	SELLA SADDLE
57GD	8AVIO REVOLUTION Campagnolo Chorus 24s DISK	Campagnolo Chorus 24s DISK	Campagnolo Chorus 24s	Campagnolo Chorus 24s DISK	Campagnolo Chorus 50/34 24s	Fulcrum Racing 400 DISK	Campagnolo Chorus 11/32 12s	Campagnolo Chorus DISK 160/160	Vittoria Zaffiro fold 700x25	Deda RHM Zero	Raxe Super Light	Raxe Alu Light 27.2	SAN MARCO Monza str
57C	8AVIO REVOLUTION Campagnolo Centaur 22s	Campagnolo Centaur 22s	Campagnolo Centaur 22s	Campagnolo Centaur 22s	Campagnolo Centaur Alu 52/36 22s	Miche RX7	Campagnolo Centaur 11/32 11s	Campagnolo Centaur	Vittoria Zaffiro fold 700x25	Deda RHM Zero	Raxe Alu Light	Raxe Alu Light 27.2	SAN MARCO Monza str
57F	8AVIO REVOLUTION Sram Force eTap AXS 24s DISK	Sram Force eTap AXS 24s DISK	Sram Force eTap AXS 24s	Sram Force eTap AXS 24s DISK	Sram Force eTap AXS 48/35 24s	Fulcrum Racing 900 DISK Miche Race DISK	Sram Force 10/28 12s	Sram Force eTap AXS DISK 160/160	Vittoria Rubino PRO fold 700x25	Deda RHM Zero	Raxe Super Light	Raxe Alu Light 27.2	SAN MARCO Monza str
57TD	8AVIO REVOLUTION Shimano Dura Ace Di2 22s DISK	Shimano Dura Ace Di2 22s DISK	Shimano Dura Ace Di2 22s	Shimano Dura Ace Di2 22s DISK	Shimano Dura Ace 52/36 22s	Miche Revox Carbon	Shimano Dura Ace 11/28-11/30 11s	Shimano 9170 Di2 DISK 140/160	Vittoria Rubino PRO fold 700x25	Deda RHM Zero 2	Deda Zero 2	Deda Zero RS	SAN MARCO Monza str
57X	8AVIO REVOLUTION Shimano Dura Ace 22s DISK	Shimano Dura Ace 22s DISK	Shimano Dura Ace 22s	Shimano Dura Ace 22s DISK	Shimano Dura Ace 52/36 22s	Fulcrum Racing 900 DISK Miche Race DISK	Shimano Dura Ace 11/28-11/30 11s	Shimano 9170 DISK 140/160	Vittoria Rubino PRO fold 700x25	Deda RHM Zero 2	Deda Zero 2	Deda Zero RS	SAN MARCO Monza str
57S	8AVIO REVOLUTION Shimano Dura Ace 22s	Shimano Dura Ace 22s	Shimano Dura Ace 22s	Shimano Dura Ace 22s	Shimano Dura Ace 52/36 22s	Fulcrum Racing 4/400	Shimano Dura Ace 11/28-11/30 11s	Shimano 9100	Vittoria Rubino PRO fold 700x25	Deda RHM Zero 2	Deda Zero 2	Deda Zero RS	SAN MARCO Monza str
57RD	8AVIO REVOLUTION Shimano Ultegra Di2 22s DISK	Shimano Ultegra Di2 22s DISK	Shimano Ultegra Di2 22s	Shimano Ultegra Di2 22s DISK	Shimano Ultegra 52/36 22s	Fulcrum Racing 900 DISK Miche Race DISK	Shimano Ultegra 11/30-11/32 11s	Shimano 8070 Di2 DISK 140/160	Vittoria Zaffiro fold 700x25	Deda RHM Zero	Raxe Super Light	Raxe Alu Light 27.2	SAN MARCO Monza str
57R	8AVIO REVOLUTION Shimano Ultegra Di2 22s	Shimano Ultegra Di2 22s	Shimano Ultegra Di2 22s	Shimano Ultegra Di2 22s	Shimano Ultegra 52/36 22s	Fulcrum Racing Sport	Shimano Ultegra 11/30-11/32 11s	Shimano 8050 Di2	Vittoria Zaffiro fold 700x25	Deda RHM Zero	Raxe Super Light	Raxe Alu Light 27.2	SAN MARCO Monza str
57Y	8AVIO REVOLUTION Shimano Ultegra 22s DISK	Shimano Ultegra 22s DISK	Shimano Ultegra 22s	Shimano Ultegra 22s DISK	Shimano Ultegra 52/36 22s	Fulcrum Racing 900 DISK Miche Race DISK	Shimano Ultegra 11/30-11/32 11s	Shimano 8070 DISK 140/160	Vittoria Zaffiro fold 700x25	Deda RHM Zero	Raxe Super Light	Raxe Alu Light 27.2	SAN MARCO Monza str
57Q	8AVIO REVOLUTION Shimano Ultegra 22s	Shimano Ultegra 22s	Shimano Ultegra 22s	Shimano Ultegra 22s	Shimano Ultegra 52/36 22s	Fulcrum Racing Sport	Shimano Ultegra 11/30-11/32 11s	Shimano 8000	Vittoria Zaffiro fold 700x25	Deda RHM Zero	Raxe Super Light	Raxe Alu Light 27.2	SAN MARCO Monza str
57D	8AVIO REVOLUTION Shimano 105 22s DISK	Shimano 105 22s DISK	Shimano 105 22s	Shimano 105 22s DISK	Shimano 105 50/34 22s	Fulcrum Racing 900 DISK Miche Race DISK	Shimano 105 11/28 11s	Shimano 7070 DISK 140/160	Vittoria Zaffiro fold 700x25	Deda RHM Zero	Raxe Alu Light	Raxe Alu Light 27.2	SAN MARCO Monza str
57O	8AVIO REVOLUTION Shimano 105 22s	Shimano 105 22s	Shimano 105 22s	Shimano 105 22s	Shimano 105 50/34 22s	Miche RX7	Shimano 105 11/28 11s	Shimano 7000	Vittoria Zaffiro fold 700x25	Deda RHM Zero	Raxe Alu Light	Raxe Alu Light 27.2	SAN MARCO Monza str
57P	8AVIO REVOLUTION Shimano 105/Ultegra Mix 22s	Shimano 105/Ultegra Mix 22s	Shimano Ultegra 22s	Shimano 105 22s	FSA Omega Megaexo Alu 34/50 22s	Miche RX7	Shimano 105 11/28 11s	Raxe R312	Vittoria Zaffiro 700x25	Deda RHM Zero	Raxe Alu Light	Raxe Alu Light 27.2	SAN MARCO Monza str
57W	8AVIO REVOLUTION Shimano Tiagra Mix 20s	Shimano Tiagra Mix 20s	Shimano Tiagra 20s	Shimano Tiagra 20s	FSA Omega Megaexo Alu 34/50 20s	Raxe T2 20s	Shimano Tiagra 11/32 10s	Raxe R312	Vittoria Zaffiro 700x25	Deda RHM Zero	Raxe Alu Light	Raxe Alu Light 27.2	SAN MARCO Monza str
57J	8AVIO REVOLUTION Shimano Tiagra Mix 20s DISK	Shimano Tiagra Mix 20s DISK	Shimano Tiagra 20s	Shimano Tiagra 20s DISK	FSA Omega Megaexo Alu 34/50 20s	Fulcrum Racing 900 DISK Miche Race DISK	Shimano Tiagra 11/32 10s	Shimano RS 405 DISK 140/160	Vittoria Zaffiro 700x25	Deda RHM Zero	Raxe Super Light	Raxe Alu Light 27.2	SAN MARCO Monza str

ZOLDER CROSS

ALLESTIMENTI / EQUIPMENTS		GRUPPO GEAR	CAMBIO REAR DERAILLEUR	COMANDI SHIFTER	GUARNITURA CHAINWHEEL	RUOTE WHEELS	CASSETTA CASSETTE	FRENI BRAKES	COPERTURE TIRES	PIEGA HANDLEBAR	PIANTONE STEM	REGGISSELLA SEAT POST	SELLA SADDLE
461	ZOLDER CROSS Shimano 105 / Ultegra Mix 22s DISK	Shimano 105/Ultegra 22s DISK	Shimano Ultegra 22s	Shimano 105 22s DISK	FSA Omega Megaexo Alu 36/46 22s	Fulcrum Racing 900 DISK Miche Race DISK	Shimano 105 11/32 11s	Shimano 7070 DISK 160/160	Schwalbe cx comp 700x30	Deda RHM Zero	Raxe Super Light	Raxe Super Light	SAN MARCO Monza str

LIEGI CROSS ALU

ALLESTIMENTI / EQUIPMENTS		GRUPPO GEAR	CAMBIO REAR DERAILLEUR	COMANDI SHIFTER	GUARNITURA CHAINWHEEL	RUOTE WHEELS	CASSETTA CASSETTE	FRENI BRAKES	COPERTURE TIRES	PIEGA HANDLEBAR	PIANTONE STEM	REGGISILLA SEAT POST	SELLA SADDLE
45N	LIEGI CROSS ALU Shimano 105 Mix 22s DISK	Shimano 105 Mix 22s DISK	Shimano 105 22s	Shimano 105 22s DISK	FSA Omega Megaexo Alu 36/46 22s	Raxe T2 22s DISK	Shimano 105 11/32 11s	Shimano 7070 DISK 140/160	Schwalbe cx comp 700x30	Deda RHM Zero	Raxe Alu Light	Raxe Alu 31.6	SAN MARCO Monza str

LEGGENDARIA

ALLESTIMENTI / EQUIPMENTS		GRUPPO GEAR	CAMBIO REAR DERAILLEUR	COMANDI SHIFTER	GUARNITURA CHAINWHEEL	RUOTE WHEELS	CASSETTA CASSETTE	FRENI BRAKES	COPERTURE TIRES	PIEGA HANDLEBAR	PIANTONE STEM	REGGISILLA SEAT POST	SELLA SADDLE
40V	LEGGENDARIA Campagnolo Potenza 22s	Campagnolo Potenza 22s SILVER	Campagnolo Potenza 22s	Campagnolo Potenza 22s	Campagnolo Potenza 22s Alu 36/52 22s	Bottecchia Silver 1980 ED 22s	Campagnolo Potenza 11/29 11s	Campagnolo Potenza silver	Vittoria Zaffiro fold 700x25	Deda SPECIALE 26 SILVER	Deda Murex 22 mm polish	Bottecchia Silver 27.2 mm	SAN MARCO Concor supercorsa
40C	LEGGENDARIA Campagnolo Centaur 22s	Campagnolo Centaur 22s	Campagnolo Centaur 22s	Campagnolo Centaur 22s	Campagnolo Centaur Alu 36/52 22s	Bottecchia Silver 1980 ED 22s	Campagnolo Centaur 11/29 11s	Campagnolo Centaur	Vittoria Zaffiro fold 700x25	Deda SPECIALE 26 SILVER	Deda Murex 22 mm polish	Bottecchia Silver 27.2 mm	SAN MARCO Concor supercorsa

GRAVEL CARBON

ALLESTIMENTI / EQUIPMENTS		GRUPPO GEAR	CAMBIO REAR DERAILLEUR	COMANDI SHIFTER	GUARNITURA CHAINWHEEL	RUOTE WHEELS	CASSETTA CASSETTE	FRENI BRAKES	COPERTURE TIRES	PIEGA HANDLEBAR	PIANTONE STEM	REGGISILLA SEAT POST	SELLA SADDLE
49Y	GRAVEL CARBON Shimano Ultegra 22s DISK	Shimano Ultegra 22s DISK	Shimano Ultegra 22s	Shimano Ultegra 22s DISK	Shimano Ultegra 36/52 22s	Fulcrum Racing 900 DISK Miche Race DISK	Shimano Ultegra 11/32 11s	Shimano 8070 DISK 140/160	CST/VRB Gravel 700x40 black	Raxe Gravel HB	Raxe Gravel	Raxe Alu 27.2	SAN MARCO Era/Monza str
49N	GRAVEL CARBON Shimano 105 Mix 22s DISK	Shimano 105 Mix 22s DISK	Shimano 105 22s	Shimano 105 22s DISK	FSA Omega Megaexo Alu 34/50 22s	Fulcrum Racing 900 DISK Miche Race DISK	Shimano 105 11/32 11s	Shimano 7070 DISK 140/160	CST/VRB Gravel 700x40 black	Raxe Gravel HB	Raxe Gravel	Raxe Alu 27.2	SAN MARCO Era/Monza str
49AP	GRAVEL CARBON Sram Apex 11s DISK	Sram Apex 11s DISK	Sram Apex 11s	Sram Apex 11s DISK	Sram Apex 42 11s	Fulcrum Racing 900 DISK Miche Race DISK	Sram Apex 11/42 11s	Sram Apex DISK	CST/VRB Gravel 700x40 black	Raxe Gravel HB	Raxe Gravel	Raxe Alu 27.2	SAN MARCO Era/Monza str

GRAVEL MONSTER

ALLESTIMENTI / EQUIPMENTS		GRUPPO GEAR	CAMBIO REAR DERAILLEUR	COMANDI SHIFTER	GUARNITURA CHAINWHEEL	RUOTE WHEELS	CASSETTA CASSETTE	FRENI BRAKES	COPERTURE TIRES	PIEGA HANDLEBAR	PIANTONE STEM	REGGISILLA SEAT POST	SELLA SADDLE
48Y	GRAVEL MONSTER Shimano Ultegra 22s DISK	Shimano Ultegra 22s DISK	Shimano Ultegra 22s	Shimano Ultegra 22s DISK	Shimano Ultegra 52/36 22s	Raxe T2 22s DISK	Shimano Ultegra 11/32 11s	Shimano 8070 DISK 140/160	CST/VRB Gravel 700x40 black	Raxe Gravel HB	Raxe Gravel	Raxe Alu 31.6	SAN MARCO Monza str
48N	GRAVEL MONSTER Shimano 105 mix 22s DISK	Shimano 105 mix 22s DISK	Shimano 105 22s	Shimano 105 22s DISK	FSA Omega Megaexo Alu 34/50 22s	Raxe T2 22s DISK	Shimano 105 11/32 11s	Shimano 7070 DISK 140/160	CST/VRB Gravel 700x40 black	Raxe Gravel HB	Raxe Gravel	Raxe Alu 31.6	SAN MARCO Monza str
48AP	GRAVEL MONSTER Sram Apex 11s DISK	Sram Apex 11s DISK	Sram Apex 11s	Sram Apex 11s DISK	Sram Apex 42 11s	Raxe T2 22s DISK	Sram Apex 11/42 11s	Sram Apex DISK	CST/VRB Gravel 700x40 black	Raxe Gravel HB	Raxe Gravel	Raxe Alu 31.6	SAN MARCO Monza str
48U	GRAVEL MONSTER Shimano Sora mix 18s DISK	Shimano Sora mix 18s DISK	Shimano Sora 18s DISK	Shimano Sora 18s DISK	FSA Omega Megaexo Alu 34/50 22s	Raxe T2 22s DISK	Shimano Sora 11/32 11s	Shimano BR317 DISK 140/160	CST/VRB Gravel 700x40 black	Raxe Gravel HB	Raxe Gravel	Raxe Alu 31.6	SAN MARCO Monza str

DUELLO

ALLESTIMENTI / EQUIPMENTS		GRUPPO GEAR	CAMBIO REAR DERAILLEUR	COMANDI SHIFTER	GUARNITURA CHAINWHEEL	RUOTE WHEELS	CASSETTA CASSETTE	FRENI BRAKES	COPERTURE TIRES	PIEGA HANDLEBAR	PIANTONE STEM	REGGISSELLA SEAT POST	SELLA SADDLE
54N	DUELLO Shimano 105 Mix 22s	Shimano 105 Mix 22s	Shimano 105 22s	Shimano 105 22s	FSA Omega Megaexo Alu 34/50 22s	Bottecchia Racing X-AIR Shimano	Shimano 105 11/30 11s	Raxe R340	CST/VRB 055 700x25 black	Deda RHM Zero	Raxe Alu Light	Raxe Alu 31.6	Bottecchia Eagle Flow
54B	DUELLO Campagnolo Veloce Mix 20s	Campagnolo Veloce Mix 20s	Campagnolo Veloce 20s	Campagnolo Veloce 20s	Bottecchia Alu 34/50	Bottecchia Racing X-AIR Campagnolo	Campagnolo Veloce 12/32 10s	Raxe R340	CST/VRB 055 700x25 black	Deda RHM Zero	Raxe Alu Light	Raxe Alu 31.6	Bottecchia Eagle Flow
54U	DUELLO Shimano Sora Mix 18s	Shimano Sora Mix 18s	Shimano Sora 18s	Shimano Sora 18s	Bottecchia Alu 34/50	Bottecchia Racing NEPAL	Shimano 11/32 9s	Raxe R340	CST/VRB 055 700x25 black	Deda RHM Zero	Raxe Alu Light	Raxe Alu 31.6	Bottecchia Eagle Flow
54K	DUELLO Shimano Claris Mix 16s	Shimano Claris Mix 16s	Shimano Claris 16s	Shimano Claris 16s	Bottecchia Alu 34/50	Bottecchia Racing NEPAL	Shimano 11/32 8s	Raxe R340	CST/VRB 055 700x25 black	Deda RHM Zero	Raxe Alu Light	Raxe Alu 31.6	Bottecchia Eagle Flow
53J	DUELLO Shimano Tiagra Mix 20s DISK	Shimano Tiagra Mix 20s DISK	Shimano Tiagra 20s	Shimano Tiagra 20s DISK	FSA Omega Megaexo Alu 34/50 22s	Raxe T2 20s DISK	Shimano Tiagra 11/32 10s	Shimano 405 DISK 140/160	CST/VRB 055 700x25 black	Deda RHM Zero	Raxe Alu Light	Raxe Alu 31.6	Bottecchia Eagle Flow

CRONOTHOLON

ALLESTIMENTI / EQUIPMENTS		GRUPPO GEAR	CAMBIO REAR DERAILLEUR	COMANDI SHIFTER	GUARNITURA CHAINWHEEL	RUOTE WHEELS	CASSETTA CASSETTE	FRENI BRAKES	COPERTURE TIRES	PIEGA HANDLEBAR	PIANTONE STEM	REGGISSELLA SEAT POST	SELLA SADDLE
77S	CRONOTHOLON Shimano Dura Ace 22s	Shimano Dura Ace 22s TT	Shimano Dura Ace 22s	Shimano Dura Ace 22s TT	Shimano Dura Ace 53/39 22s	Fulcrum Racing 4 Carbon	Shimano Dura Ace 11/25 11s	Special Integrated CRONOTHOLON	Vittoria clincher SPEED TLR G+ 700x25	Special Integrated CRONOTHOLON	Special Integrated CRONOTHOLON	CRONOTHOLON Aero triat/crono	SAN MARCO short fit dyn
77R	CRONOTHOLON Shimano Ultegra Di2 22s	Shimano Ultegra Di2 22s TT	Shimano Ultegra Di2 22s	Shimano Ultegra Di2 22s TT	Shimano Ultegra 52/36 22s	Miche Revox Carbon	Shimano Ultegra 11/25 11s	Special Integrated CRONOTHOLON	Vittoria Zaffiro fold 700x25	Special Integrated CRONOTHOLON	Special Integrated CRONOTHOLON	CRONOTHOLON Aero triat/crono	SAN MARCO short fit dyn
77Q	CRONOTHOLON Shimano Ultegra 22s	Shimano Ultegra 22s TT	Shimano Ultegra 22s	Shimano Ultegra 22s TT	Shimano Ultegra 52/36 22s	Fulcrum Racing 4/400	Shimano Ultegra 11/25 11s	Special Integrated CRONOTHOLON	Vittoria Zaffiro fold 700x25	Special Integrated CRONOTHOLON	Special Integrated CRONOTHOLON	CRONOTHOLON Aero triat/crono	SAN MARCO short fit dyn

AQUILA ROSSA

ALLESTIMENTI / EQUIPMENTS		FORCELLA FORK	GRUPPO GEAR	CAMBIO R.DERAILL.	COMANDI SHIFTER	GUARNITURA CHAINWHEEL	RUOTE WHEELS	CASSETTA CASSETTE	FRENI BRAKES	COPERTURE TIRES	PIEGA HANDLEBAR	PIANTONE STEM	REGGISSELLA SEATPOST	SELLA SADDLE
79N	AQUILAROSSA Sram X01 eTap AXS 12s	RS SID 29 Boost RL 100mm	Sram X01 eTap AXS 12s	Sram X01 eTap AXS 12s	Sram X01 eTap AXS 12s	Sram X01 eTap AXS 34t 12s	Fulcrum Red Zone 500 XD BOOST	Sram X01 eTap AXS 10/50 12s	Shimano XT 8100	Vittoria Barzo 29x2.25 fold/ Swalbe	Ritchey WCS 31.8 flat	Ritchey WCS 4-axis	Ritchey WCS 31.6x400	SAN MARCO Mantra RED LAB
79R	AQUILAROSSA Sram XX1/X01 12s	RS SID 29 Boost RL 100mm	Sram XX1/X01 12s	Sram XX1 12s	Sram X01 12s	Sram XX1 34t 12s	Fulcrum Red Zone 500 XD BOOST	Sram X01 10/50 12s	Shimano XT 8100	Vittoria Barzo 29x2.25 fold/ Swalbe	Ritchey WCS 31.8 flat	Ritchey WCS 4-axis	Ritchey WCS 31.6x400	SAN MARCO Mantra RED LAB
79T	AQUILAROSSA Sram X01/GX 12s	RS SID 29 Boost RL 100mm	Sram X01/GX 12s	Sram X01 12s	Sram GX 12s	Sram GX 32t 12s	Fulcrum Red Zone 700 XD BOOST	Sram GX 10/50 12s	Shimano BR-MT500	Vittoria Barzo 29x2.25/Swalbe	Ritchey 31.8 flat	Ritchey 4-axis	Ritchey 31.6x400	SAN MARCO Mantra RED LAB
79F	AQUILAROSSA Shimano XTR 12s	FOX 29 Float Kashima FS 100 BK	Shimano XTR 12s	Shimano XTR 12s	Shimano XTR 12s	Shimano XTR 34t 12s	DRC Shimano MT 900 12s	Shimano XTR 10/51 12s	Shimano XTR 9100	Vittoria Barzo 29x2.25 fold/ Swalbe	Ritchey WCS 31.8 flat	Ritchey WCS 4-axis	Ritchey WCS 31.6x400	SAN MARCO Mantra CARBON
79Q	AQUILAROSSA Shimano XT 12s	RS SID 29 Boost RL 100mm	Shimano XT 12s	Shimano XT 12s	Shimano XT 12s	Shimano XT 32t 12s	DRC Shimano MT 400 12s	Shimano XT 10/51 12s	Shimano XT 8100	Vittoria Barzo 29x2.25/Swalbe	Ritchey 31.8 flat	Ritchey 4-axis	Ritchey 31.6x400	SAN MARCO Mantra RED LAB

ORTLES 297+

ALLESTIMENTI / EQUIPMENTS		FORCELLA FORK	GRUPPO GEAR	CAMBIO R.DERAILL.	COMANDI SHIFTER	GUARNITURA CHAINWHEEL	RUOTE WHEELS	CASSETTA CASSETTE	FRENI BRAKES	COPERTURE TIRES	PIEGA HANDLEBAR	PIANTONE STEM	REGGISSELLA SEATPOST	SELLA SADDLE
83N	ORTLES 297+ Sram X01 eTap AXS 12s	RS Reba RL 29 Boost 100 PL	Sram X01 eTap AXS 12s	Sram X01 eTap AXS 12s	Sram X01 eTap AXS 12s	Sram X01 eTap AXS 34t 12s	Fulcrum Red Zone 700 XD BOOST	Sram X01 eTap AXS 10/50 12s	Shimano XT 8100	Vittoria Barzo 29x2.25 Fold/ Swalbe	Ritchey WCS 31,8 flat	Ritchey WCS 4-axis	Ritchey WCS 30,9x400	SAN MARCO Aspide2 RED LAB
83R	ORTLES 297+ Sram XX1/X01 12s	RS Reba RL 29 Boost 100 PL	Sram XX1/X01 12s	Sram XX1 12s	Sram X01 12s	Sram XX1 34t 12s	Fulcrum Red Zone 700 XD BOOST	Sram XX1 10/50 12s	Shimano XT 8100	Vittoria Barzo 29x2.25 Fold/ Swalbe	Ritchey WCS 31,8 flat	Ritchey WCS 4-axis	Ritchey WCS 30,9x400	SAN MARCO Aspide2 RED LAB
83T	ORTLES 297+ Sram X01/GX 12s	RS Recon sil 29 Boost 100 PL	Sram X01/GX 12s	Sram X01 12s	Sram GX 12s	Sram GX 32t 12s	Fulcrum Red Zone 700 XD BOOST	Sram GX 10/50 12s	Shimano BR-MT500	Vittoria Barzo 29x2.25/Swalbe	Ritchey 31,8 flat	Ritchey 4-axis	Ritchey 30,9x400	SAN MARCO Aspide2 RED LAB
83U	ORTLES 297+ Sram NX1 12s	RS Recon sil 29 Boost 100 PL	Sram NX1 12s	Sram NX1 12s	Sram NX1 12s	Sram NX1 32t 12s	Fulcrum Red Zone 700 BOOST	Sram NX1 11/50 12s	Shimano BR-MT500	Vittoria Barzo 29x2.25/Swalbe	Raxe Alu 31,8 flat	Raxe Super Light	Raxe Super Light 30,9x400	SAN MARCO Monza str
83V	ORTLES 297+ Sram SX 12s	RS Recon sil 29 Boost 100 PL	Sram SX 12s	Sram SX 12s	Sram SX 12s	Sram SX 32t 12s	Raxe 29 TL30 BOOST	Sram SX 11/50 12s	Shimano BR-MT200	Vittoria Barzo 29x2.25/Swalbe	Raxe Alu 31,8 flat	Raxe Super Light	Raxe Super Light 30,9x400	SAN MARCO Monza str
83Q	ORTLES 297+ Shimano XT 12s	RS Reba RL 29 Boost 100 PL	Shimano XT 12s	Shimano XT 12s	Shimano XT 12s	Shimano XT 32t 12s	DRC Shimano MT 400 12s	Shimano XT 10/51 12s	Shimano XT 8100	Vittoria Barzo 29x2.25 Fold/ Swalbe	Ritchey 31,8 flat	Ritchey 4-axis	Ritchey 30,9x400	SAN MARCO Aspide2 RED LAB
83A	ORTLES 297+ Shimano XT/DEORE 20s	RS 30 Silver TK Air 29 100mm PL	Shimano XT/DEORE 20s	Shimano XT 20s	Shimano DEORE 20s	Vortex 551 24/38t	Raxe 29 TL30	Shimano DEORE HG 50 11/36 10s	Shimano BR-MT200	Vittoria Barzo 29x2.25/Swalbe	Raxe Alu 31,8 flat	Raxe Super Light	Raxe Super Light 30,9x400	SAN MARCO Monza str

STELVIO 297+

ALLESTIMENTI / EQUIPMENTS		FORCELLA FORK	GRUPPO GEAR	CAMBIO R.DERAILL.	COMANDI SHIFTER	GUARNITURA CHAINWHEEL	RUOTE WHEELS	CASSETTA CASSETTE	FRENI BRAKES	COPERTURE TIRES	PIEGA HANDLEBAR	PIANTONE STEM	REGGISSELLA SEATPOST	SELLA SADDLE
85C	STELVIO 297+ Shimano XT 22s	RS Recon RL 29 100mm PL	Shimano XT 22s	Shimano XT 11s	Shimano XT 22s	Shimano XT 38/28t	Raxe 29 TL30	Shimano XT 11/42	Shimano BR-MT500	Vittoria Barzo 29x2.25/Swalbe	Raxe Alu Light 31,8 flat	Raxe Super Light	Raxe Super Light 31,6x400	SAN MARCO Monza str
85Q	STELVIO 297+ Shimano XT 12s	RS Recon sil 29 Boost 100 PL	Shimano XT 12s	Shimano XT 12s	Shimano XT 12s	Shimano XT 32t 12s	Raxe 29 TL30	Shimano XT 10/51 12s	Shimano BR-MT500	Vittoria Barzo 29x2.25/Swalbe	Raxe Alu Light 31,8 flat	Raxe Super Light	Raxe Super Light 31,6x400	SAN MARCO Monza str
85A	STELVIO 297+ Shimano XT/DEORE 20s	RS 30 Silver tk air 29 100mm PL	Shimano XT/DEORE 20s	Shimano XT 10s	Shimano DEORE 20s	Vortex 551 24/38t	Raxe 29 TL30	Shimano DEORE HG 50 11/36 10s	Shimano BR-MT200	Vittoria Barzo 29x2.25/Swalbe	Raxe Alu Light 31,8 flat	Raxe Super Light	Raxe Super Light 31,6x400	SAN MARCO Monza str
85W	STELVIO 297+ Sram GX/SX 12s	RS Recon sil 29 Boost 100 PL	Sram GX/SX 12s	Sram GX 12s	Sram SX 12s	Sram SX 32t 12s	Raxe 29 TL30	Sram SX 11/50 12s	Shimano BR-MT500	Vittoria Barzo 29x2.25/Swalbe	Raxe Alu Light 31,8 flat	Raxe Super Light	Raxe Super Light 31,6x400	SAN MARCO Monza str
85V	STELVIO 297+ Sram SX 12s	RS 30 Silver tk air 29 100mm PL	Sram SX 12s	Sram SX 12s	Sram SX 12s	Sram SX 32t 12s	Raxe 29 TL30	Sram SX 11/50 12s	Shimano BR-MT200	Vittoria Barzo 29x2.25/Swalbe	Raxe Alu 31,8 flat	Raxe Super Light	Raxe Super Light 31,6x400	SAN MARCO Monza str
85S	STELVIO 297+ Sram NX1 11s	RS 30 Silver tk air 29 100mm PL	Sram NX1 11s	Sram NX1 11s	Sram NX1 11s	MPX11 32t 11s	Raxe 29 TL30	Sram NX1 11/42 11s	Shimano BR-MT200	Vittoria Barzo 29x2.25/Swalbe	Raxe Alu Light 31,8 flat	Raxe Super Light	Raxe Super Light 31,6x400	SAN MARCO Monza str

GAVIA

ALLESTIMENTI / EQUIPMENTS		FORCELLA FORK	GRUPPO GEAR	CAMBIO R.DERAILL.	COMANDI SHIFTER	GUARNITURA CHAINWHEEL	RUOTE WHEELS	CASSETTA CASSETTE	FRENI BRAKES	COPERTURE TIRES	PIEGA HANDLEBAR	PIANTONE STEM	REGGISSELLA SEATPOST	SELLA SADDLE
87V	GAVIA 29 Sram SX 12s	RS XC 30 TK 100 RL	Sram SX 12s	Sram SX 12s	Sram SX 12s	Sram SX 32t 12s	Raxe 29 TL30	Sram SX 11/50 12s	Shimano BR-MT200	Vittoria Barzo 29x2.25/Swalbe	Raxe Alu Light 31,8 flat	Raxe Super Light	Raxe Alu light 31,6x350	SAN MARCO Monza str
87A	GAVIA 29 Shimano XT/DEORE 20s	Suntour XCM 29 RL 100mm	Shimano XT/DEORE 20s	Shimano XT 20s	Shimano DEORE 20s	Suntour XCM 38/24 20s	Raxe 29 TL30	Shimano DEORE HG 50 11/42 10s	Shimano BR-MT200	Vittoria Barzo 29x2.25/Swalbe	Raxe Alu Light 31,8 flat	Raxe Super Light	Raxe Alu light 31,6x350	SAN MARCO Monza str

TONALE

ALLESTIMENTI / EQUIPMENTS		FORCELLA FORK	GRUPPO GEAR	CAMBIO R.DERAILL.	COMANDI SHIFTER	GUARNITURA CHAINWHEEL	RUOTE WHEELS	CASSETTA CASSETTE	FRENI BRAKES	COPERTURE TIRES	PIEGA HANDLEBAR	PIANTONE STEM	REGGISSELLA SEATPOST	SELLA SADDLE
89E	TONALE 29 Shimano Alivio 27s	Suntour XCM 29 RL 100mm	Shimano Alivio Mix 27s	Shimano Alivio 27s	Shimano SLM 370	Suntour XCT 44/32/22 27s	Raxe 29 TL30	Shimano HG 200 11/32 9s	Shimano BR-MT200	Vittoria Barzo 29x2.25/Swalbe	Raxe Alu Light 31,8 flat	Raxe Super Light	Raxe Alu light 31,6x350	Botteccia Team Pro

GARDENA 29"

ALLESTIMENTI / EQUIPMENTS		FORCELLA FORK	AMMORT. REAR SHOX	GRUPPO GEAR	CAMBIO R.DERAILL.	COMANDI SHIFTER	GUARNITURA CHAINWHEEL	RUOTE WHEELS	CASSETTA CASSETTE	FRENI BRAKES	COPERTURE TIRES	PIEGA HANDLEBAR	PIANTONE STEM	REGGISSELLA SEATPOST	SELLA SADDLE
91F	GARDENA 29 BOOST Shimano XTR 12s	FOX 29 Float Kashima FS 100 BK	RS Monarch RL mnr 165mm	Shimano XTR 12s	Shimano XTR 12s	Shimano XTR 12s	Shimano XTR 34t 12s	DRC Shimano MT900 12s BOOST	Shimano XTR 10/51 12s	Shimano XTR M9100	Vittoria Barzo 29x2.25 Fold/ Swalbe	Ritchey WCS 31,8 flat	Ritchey WCS 4-axis	Tranz-x regolabile 31,6	SAN MARCO Aspide CARBON
91Q	GARDENA 29 BOOST Shimano XT 12s	RS Reba RL 29 Boost 100 PL	RS Monarch RL mnr 165mm	Shimano XT 12s	Shimano XT 12s	Shimano XT 12s	Shimano XT 32t 12s	DRC Shimano MT 400 12s BOOST	Shimano XT 10/51 12s	Shimano XT M8100	Vittoria Barzo 29x2.25/Swalbe	Ritchey 31,8 flat	Ritchey 4-axis	Tranz-x regolabile 31,6	SAN MARCO Mantra RED LAB
91R	GARDENA 29 BOOST Sram XX1/X01 12S	RS Sid Boost RL 29 100mm	RS Monarch RL mnr 165mm	Sram XX1/X01 12S	Sram XX1 12S	Sram X01 12S	Sram XX1 34t 12s	Fulcrum Red Zone 700 BOOST XD	Sram X01 10/50 12s	Shimano XT M8100	Vittoria Barzo 29x2.25 Fold/ Swalbe	Ritchey WCS 31,8 flat	Ritchey WCS 4-axis	Tranz-x regolabile 31,6	SAN MARCO Mantra RED LAB
91T	GARDENA 29 BOOST Sram X01/GX 12s	RS Reba RL 29 Boost 100 PL	RS Monarch RL mnr 165mm	Sram X01/GX 12s	Sram X01 12s	Sram GX 12s	Sram GX 32t 12s	Fulcrum Red Zone 700 BOOST XD	Sram GX 10/50 12s	Shimano XT M8100	Vittoria Barzo 29x2.25/Swalbe	Ritchey 31,8 flat	Ritchey 4-axis	Tranz-x regolabile 31,6	SAN MARCO Mantra RED LAB
91W	GARDENA 29 BOOST Sram GX/SX 12s	RS Reba RL 29 Boost 100 PL	RS Monarch RL mnr 165mm	Sram GX/SX 12s	Sram GX 12s	Sram SX 12s	Sram SX 32t 12s	Raxe 29 TL30 BOOST	Sram SX 11/50 12s	Shimano BR-MT500	Vittoria Barzo 29x2.25/Swalbe	Ritchey 31,8 flat	Ritchey 4-axis	Raxe Super Light 31,6	SAN MARCO Monza str

FEDAIA 27,5"

ALLESTIMENTI / EQUIPMENTS		FORCELLA FORK	AMMORT. REAR SHOX	GRUPPO GEAR	CAMBIO R.DERAILL.	COMANDI SHIFTER	GUARNITURA CHAINWHEEL	RUOTE WHEELS	CASSETTA CASSETTE	FRENI BRAKES	COPERTURE TIRES	PIEGA HANDLEBAR	PIANTONE STEM	REGGISSELLA SEATPOST	SELLA SADDLE
95T	FEDAIA 27.5 Sram X01/GX 12s	PIKE 27,5 150mm axle 15	RS Monarch RL mnr 200mm	Sram X01/GX 12s	Sram X01 12s	Sram GX 12s	Sram GX 32t 12s	Fulcrum Red Power 27,5	Sram GX 10/50 12s	Shimano XT M8100	VEE-TIRE-CO 27,5x2,35	Ritchey 31,8 flat	Ritchey 4-axis	PRO MAX adjustable 31,6	SAN MARCO Aspide2 RED LAB
95W	FEDAIA 27.5 Sram GX/SX 12s	PIKE 27,5 150mm axle 15	RS Monarch RL mnr 200mm	Sram GX/SX 12s	Sram GX 12s	Sram SX 12s	Sram SX 32t 12s	Fulcrum Red Power 27,5	Sram SX 11/50 12s	Shimano XT M8100	VEE-TIRE-CO 27,5x2,35	Raxe Alu 31,8 flat	Raxe Alu light	PRO MAX adjustable 31,6	SAN MARCO Aspide2 RED LAB

CERVINO

ALLESTIMENTI / EQUIPMENTS		FORCELLA FORK	GRUPPO GEAR	CAMBIO R.DERAILL.	COMANDI SHIFTER	GUARNITURA CHAINWHEEL	RUOTE WHEELS	CASSETTA CASSETTE	FRENI BRAKES	COPERTURE TIRES	PIEGA HANDLEBAR	PIANTONE STEM	REGGISSELLA SEATPOST	SELLA SADDLE
145	CERVINO FAT 26 Shimano XT/DEORE 20s	Fat 26" Carbon	Shimano XT/DEORE 20s	Shimano XT 20s	Shimano DEORE 20s	Suntour XCM 38/24 20s	Fat 26x4,00 Alu 36f	Shimano DEORE HG 50 11/36 10s	Shimano DEORE 615 160/180	Vee Tire Co. 26x4,00 Fold	Raxe Alu 31,8 flat	Raxe Alu light	Raxe Alu 31,6x350	Bottecchia Pro Team

SENALES

ALLESTIMENTI / EQUIPMENTS		FORCELLA FORK	GRUPPO GEAR	CAMBIO R.DERAILL.	COMANDI SHIFTER	GUARNITURA CHAINWHEEL	RUOTE WHEELS	CASSETTA CASSETTE	FRENI BRAKES	COPERTURE TIRES	PIEGA HANDLEBAR	PIANTONE STEM	REGGISSELLA SEATPOST	SELLA SADDLE
140	SENALES FAT 26 Shimano Alivio 18s	Fat 26" Alluminio	Shimano Alivio Mix 18s	Shimano Alivio 18s	Shimano SLM 370	Suntour XCM 38/24 18s	Fat 26x4,00 Alu 36f	Shimano HG 200 11/34 9s	Shimano BR-MT200	Vee Tire Co. 26x4,00	Raxe Alu 31,8 flat	Raxe Alu	Raxe Alu 31,6x350	Bottecchia Eagle Flow

WORLD DISTRIBUTORS

AGENT FOR AUSTRIA

GALLIZIA FRANCO
N.10 OKTOBER STR., 7
9800 SPITTAL AN DER DRAU
TEL: +43 6647821217
gallizia@aon.at

AGENT FOR BELGIUM

RENAUD MATUS
THIER 12
4890 CLERMONT BELGIUM
TEL: +32 478280436
renaud@matus.be

CHINA

SHENYANG COHESION TRADING
CO. LTD
NO. 128 BEIZHONGJIE STREET,
SHENHE DISTRICT
SHENYANG - LIAONING
TEL: +86 24841451
syheima@126.com

CHILE

BIKE UNIVERSE
TOBALABA 4073 LOCAL 102
PROVIDENCIA
SANTIAGO DE CHILE
TEL: +56 957102610
contacto@bikeuniverse.cl
www.bikeuniverse.cl

CROATIA

GOLF AURORA
GORNJE M. POLJE 39, GORNJE
MRZLO POLJE
47250 MREZNICKO DUGA RESA
TEL: +38 547844037
info@golf-aurora.hr

CYPRUS

MIKELLIDI ELENI
GEORGIOU KATSOURI, 26
2040 STROVOLOS
TEL: +35 799680372
andreouxaris@gmail.com

CZECH REPUBLIC

LOM TRADING - ING.EVA LOMOVA
POD JAROVEM 2035/26
13000 PRAHA 3
TEL: +42 0296365556
eva.lomova@lomtrading.cz

DENMARK

EBSEN DANMARK A/S
INDUSTRI PARKEN 8
DK-6500
VOJENS
TEL: +45 74541819
FAX: +45 74542919
pse@ebesen-danmark.dk
www.ebsen-danmark.dk

AGENT FOR DOMTOM

MIREILLE HERNANDEZ
M3 BOULEVARD OLIVIER DE SERRES
30133 LES ANGES
TEL: +33 (0)6 20681321
mhextotica@orange.fr

ESTONIA-LATVIA-LITHUANIA

SPORTLAND EESTI AS,
PARNU MNT, 142A, 11317 TALLIN,
ESTONIA
TEL: +37 26548434
FAX: +37 26548401
info@sportland.ee
www.sportland.ee

FINLAND

BIKEIMPORT FINLAND
OLARINLUOMA 20
2200 ESPOO
FINLAND
TEL: +358 405160597
jari@bikeimport.fi

AGENT FOR FRANCE

DANIEL RIPOLL
13 RUE RENE DE FILIPPI
93700 DRANCY
FRANCE
TEL: +33 660500438
danieldr21@hotmail.fr

GERMANY AND POLAND

BBF BIKE GMBH
CARENAALLEE, 8 - 15366
HOPPEGARTEN
TEL: +49 3342354325
FAX: +49 3342354332
info@bbf-bike.de
www.bbf-bike.com

GREECE

PANAGIOTIS M. KASPARIS
60 SOLODOS STR.
THESSALONIKI
MACEDONIA
TEL: +30 2310852762
info@podilato.eu

GUATEMALA

BICI AVENTURA
20 CALLE 24/67 ZONA 10, LOCAL 5,
CENTRO COMERCIAL PARIS PLAZA
CITTA DEL GUATEMALA
TEL: +50 223666647
www.biciaventura.com.gt

HUNGARY

TUTTO BICI KFT
SZABADSAG TER 22
2045 TOROKBALINT
HUNGARY
TEL: +36 209629393
tuttobici69@gmail.com

INDIA

WHITE ROSE IMPEX
703 RNA CLASSIC, S.V. ROAD
SANTACRUZ WEST
400054 MUMBAI INDIA
TEL: +91 2226438529
laiquegadhwal@yahoo.com

INDONESIA

BANDUNG S.A.
JL: INGGIT GARNASIH NO.111
40252 BANDUNG
TEL: +62 (022) 5200559
hkuntadi@centrih.net.id

IRAN

DATIS KHODRO
DIBA BUILDING NO.2, TWENTIESH
ST. FARHANG BLVD.
SAADAT ABAD, TEHRAN
IRAN
TEL: +98 2175306
cc@datisworldwide.com

IRELAND

CHAIN DRIVEN CYCLES
23 HIGH ST. - SLIGO
TEL: +35 3719129008
stephen@chaindrivencycles.com

ISRAEL

AD-EL AUTOMOBILE SERVICE LTD
2 BEN-ZVI ST. - 68181
TEL AVIV
TEL: +97 236829922
adelrom@netvision.net.il

JAPAN

GLOBERIDE INC.
3-14-16 MAESAWA HIGASHIKURUME
TOKIO 203-8511
TEL: +81 414797756
y_asai@globeride.co.jp

MALTA

MEDUSA TRADING LTD
TRIQ I'LL KAJJIK, ZTN09
MARSAXLOKK, MALTA
TEL: +35 62766 1166
FAX: +35 62766 1166
jack@thecyclistmalta.com

NEW ZEALAND

ELECTRIFY.NZ
5 SCOTLAND ST,
AUCKLAND
TEL: +09 8892019
michael@electrify.nz
www.electrify.nz

NORWAY

VANOR AS - NRP SPORT
BRUGATA 19
2380 BRUMUNDDAL
TEL: +47 95138510
post@nrpsport.no

SLOVAKIA

RACING BIKES S.R.O. - SPEZZOTTO
VYSEHRADSKA, 29
BRATISLAVA (BRATISLAVA)
TEL: +42 1903207806
falange@mail.t-com.sk

AGENT FOR SPAIN - CATALONIA (CATALUÑA), ARAGÓN, CASTELLÓN

DANIEL LOPEZ CASEIRO
TEL: +34 608283009
danijsaca71@gmail.com

AGENT FOR SPAIN - VALENCIA, ALBACETE, ALICANTE, MURCIA

CRISTIAN CORCOLES ALFONSO
TEL: +34 692326222
Cristiancorcoles18@icloud.com

SWITZERLAND

DNT RACING SAGL
VIA COSTA DI FUORI 15
CH- BRISSAGO 6614
TE: +41 917913214
info@youtuning.com
www.youtuning.com

TURKEY

ST GRUP
ORGANIZE SANAYI BOLGESI, VALI
MUNIR GUNAY CADESİ, NO.6,1
KISIM, 20330 DENIZLI
TEL: +90 2582515151
FAX: +90 2582514200
import@stgroup.com.tr
www.stgroup.com.tr

UK

REECE CYCLES
100 ALCESTER STREET
BIRMINGHAM B12 0QB
TEL: +44 7860627103
sales@reececycles.co.uk

UKRAINE

RICH SPORT
8, EKATERININSKAYA SQUARE
ODESSA 65026
TEL: +38 0487193982
info@richsport.com.ua
www.richsport.ua

USA

GIZMO GEAR
3415 W. LAKE MEAD BLVD.
BUILDING 115,
N. LAS VEGAS, NV
TEL: +17 023419004
bill@gizmogear.biz

Bottecchia Cicli s.r.l. si riserva la facoltà di apportare modifiche senza alcun obbligo di preavviso, avendo come politica la ricerca di continui miglioramenti qualitativi ed estetici, per cui non dà diritto a reclami e rimborsi di alcun genere. Bottecchia è un marchio registrato.

Bottecchia Cicli s.r.l. reserves the right to make modifications without any obligation to give prior notice, in line with its policy of continuous improvement in terms of quality and appearance, which therefore does not give right of any kind to make claims or ask for reimbursement. Bottecchia is a trade mark.

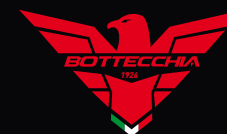

BOTTECCHIA®

Bottecchia Cicli s.r.l

viale Enzo Ferrari, 15/17
30014 Cavarzere
Venezia - Italy
www.bottecchia.com

COMMERCIALE ITALIA

Tel. +39 0426 311724
Fax +39 0426 311710
info@bottecchia.com

EXPORT SALES DEPARTMENT

Tel. +39 0426 311727
Fax +39 0426 311710
sales@bottecchia.com

PURCHASE DEPARTMENT

Tel. +39 0426 318392
Fax +39 0426 318868
import@bottecchia.com

